

737-200

StartupBoeing



# 737-200 General Arrangement

StartupBoeing

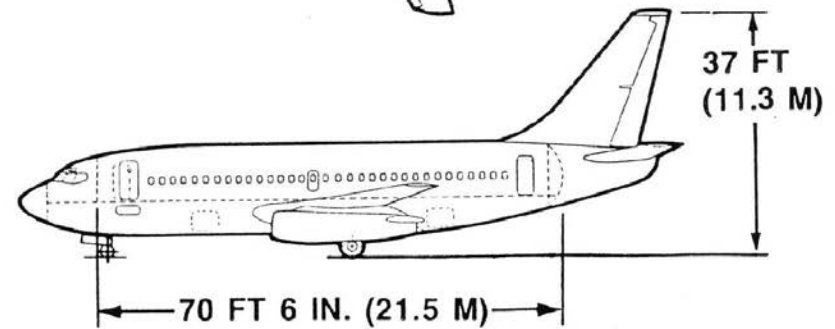
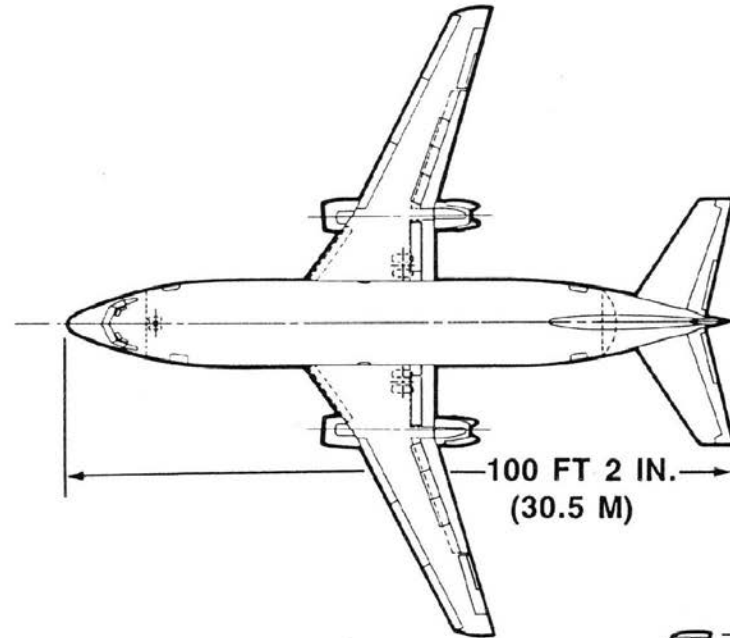
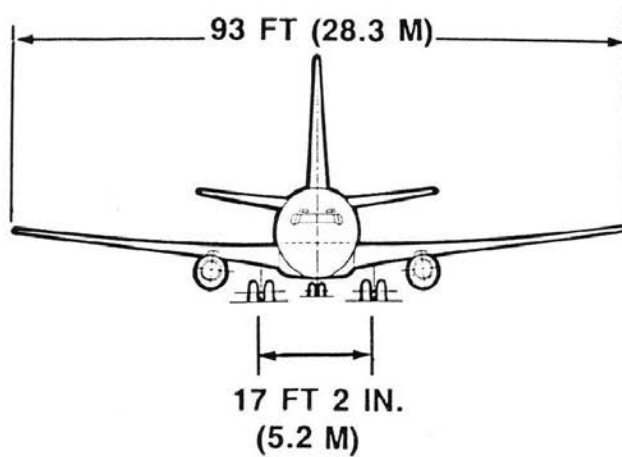



# 737-200C

StartupBoeing



# 737-200 Airstairs

StartupBoeing

Forward

Aft





# 737-200 Thrust Reverser

StartupBoeing

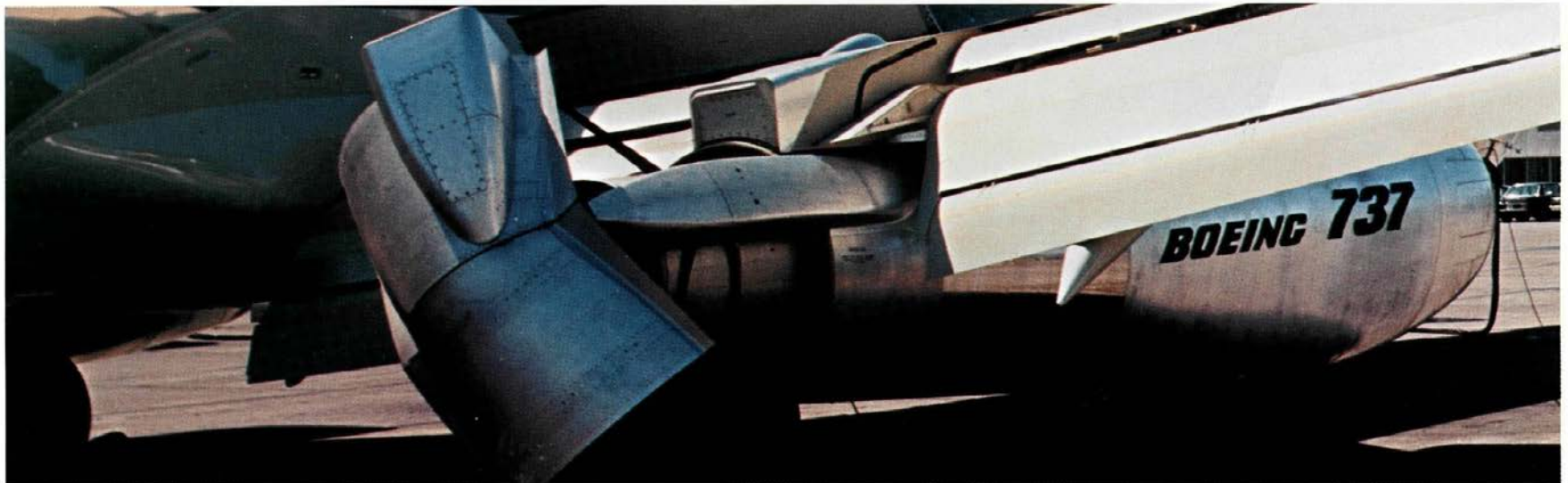
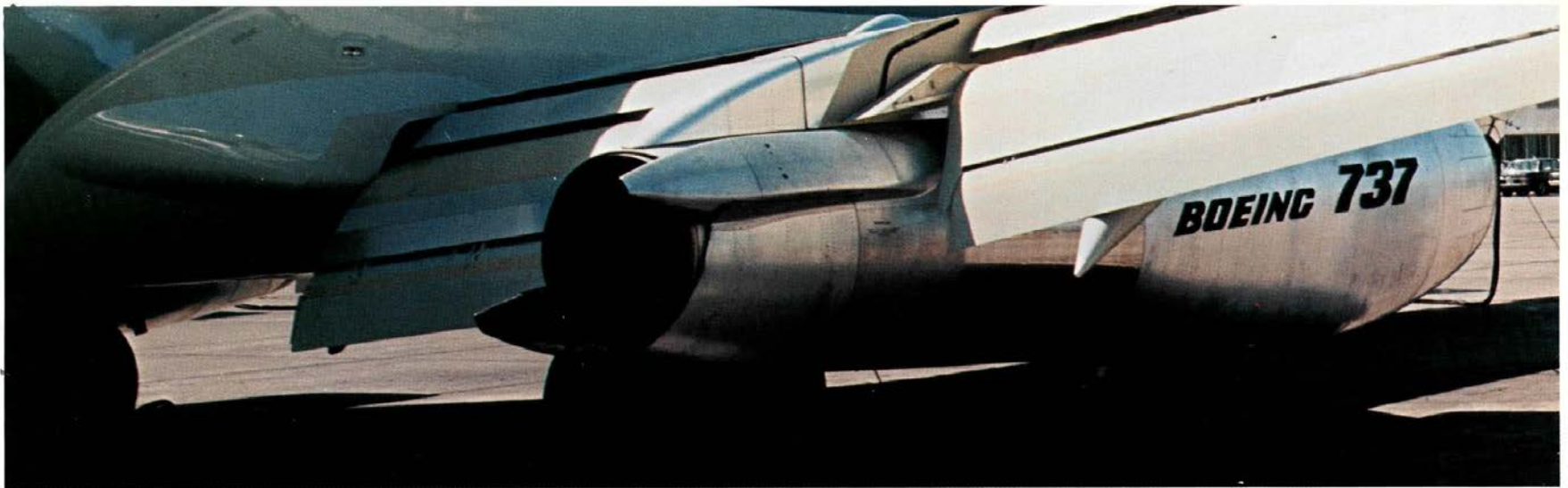

# 737-200 Interior Arrangements

StartupBoeing

**38/32-INCH  
SEAT PITCH**

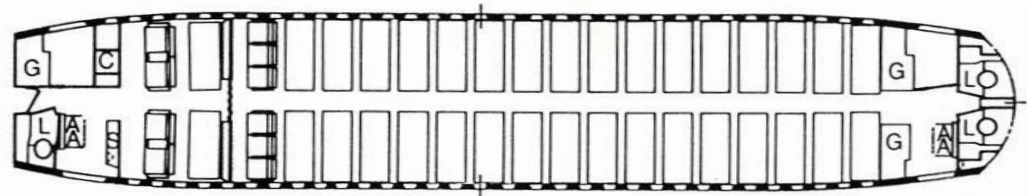

**8 FIRST CLASS**

**102 TOURIST**

**110 PASSENGERS**

**32-INCH  
SEAT PITCH**

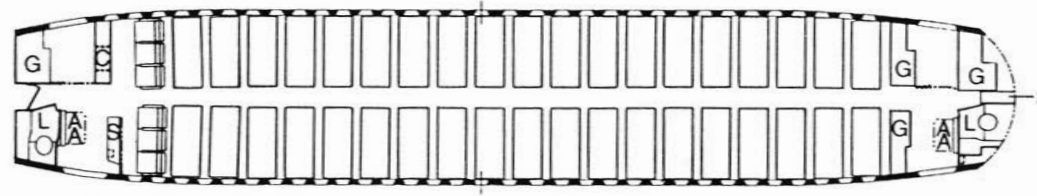

**120 TOURIST PASSENGERS**

**30-INCH  
SEAT PITCH**

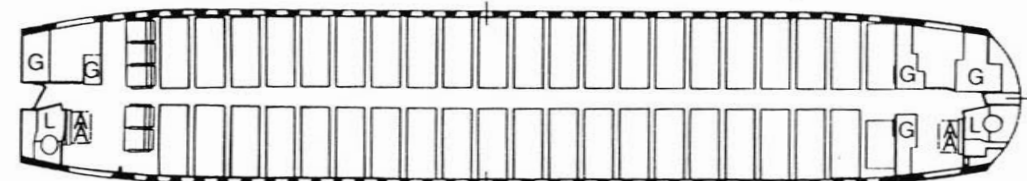

**130 TOURIST PASSENGERS**

A = ATTENDANT  
C = CLOSET  
G = GALLEY  
L = LAVATORY  
S = STOWAGE



# 737-200 Interior

StartupBoeing



# 737-200 Combi Interior Arrangements

StartupBoeing

## CONFIGURATIONS TO MATCH PASSENGER AND CARGO REQUIREMENTS OF MANY ROUTES

**2 PALLETS/81 PASSENGERS,  
SIX ABREAST AT 32-IN. PITCH (TYPICAL)  
CARGO VOLUME 1580.0 FT<sup>3</sup> (44.7 M<sup>3</sup>)**

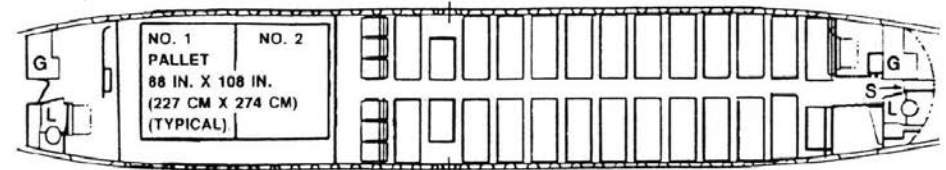

**3 PALLETS/65 PASSENGERS  
CARGO VOLUME 1932.5 FT<sup>3</sup> (54.7 M<sup>3</sup>)**

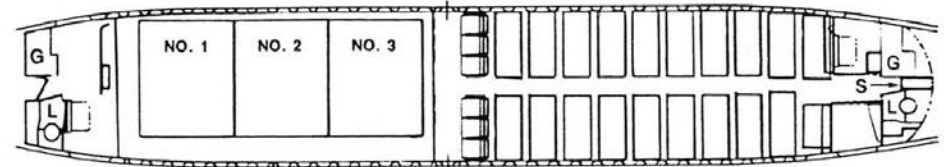

**4 PALLETS/35 PASSENGERS  
CARGO VOLUME 2285.0 FT<sup>3</sup> (64.7 M<sup>3</sup>)**

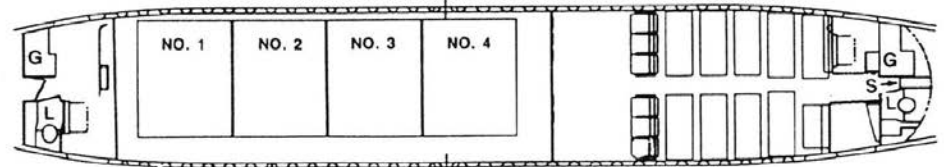

**5 PALLETS/29 PASSENGERS  
CARGO VOLUME 2637.5 FT<sup>3</sup> (74.6 M<sup>3</sup>)**

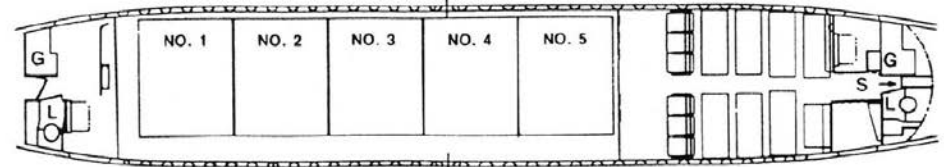

**6 PALLETS/11 PASSENGERS  
CARGO VOLUME 2990.0 FT<sup>3</sup> (84.6 M<sup>3</sup>)**

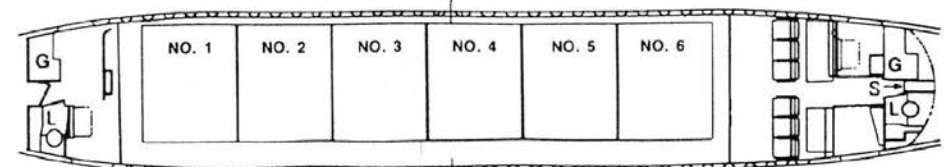



# 737-200 Quick Change Interior

StartupBoeing

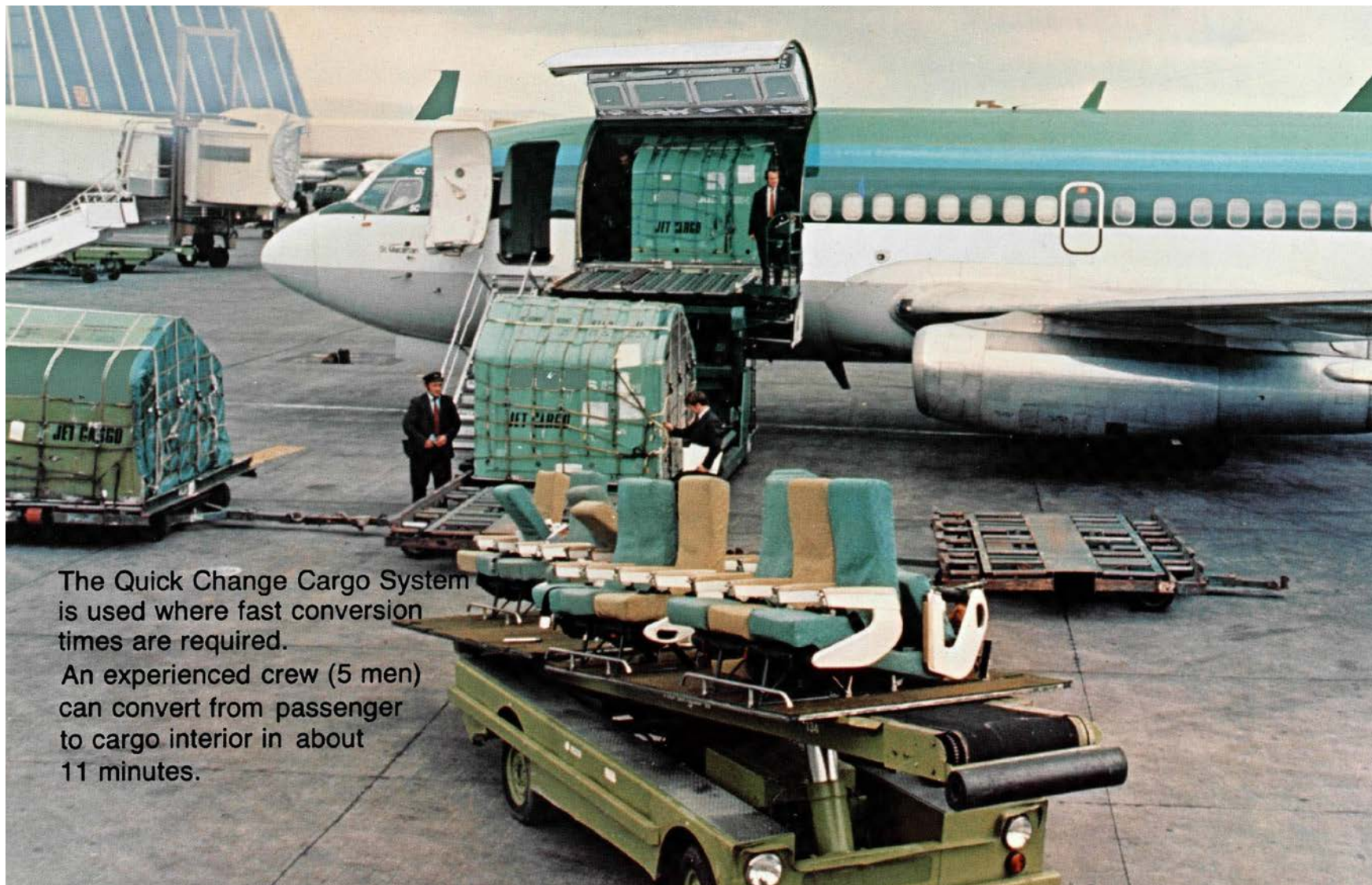

The Quick Change Cargo System is used where fast conversion times are required.

An experienced crew (5 men) can convert from passenger to cargo interior in about 11 minutes.

# 737-200C Cargo Arrangement

StartupBoeing

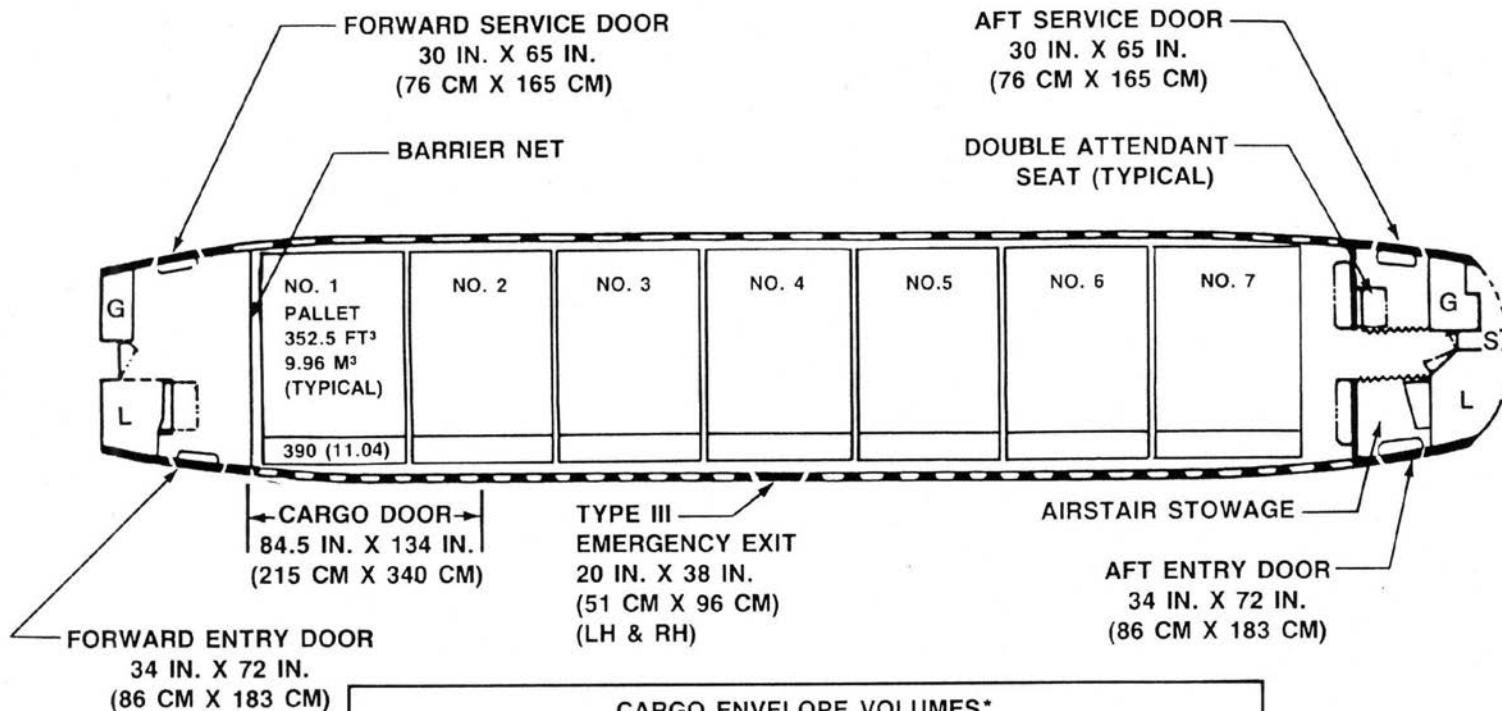

CARGO ENVELOPE VOLUMES*		
PALLET SIZE	88 IN. X 108 IN. (224 CM X 274 CM)	88 IN. X 125 IN. (224 CM X 317 CM)
PALLET 1-7	2468 FT <sup>3</sup> (69.8 M <sup>3</sup> )	2730 FT <sup>3</sup> (77.2 M <sup>3</sup> )
LOWER DECK	875 FT <sup>3</sup> (24.8 M <sup>3</sup> )	875 FT <sup>3</sup> (24.8 M <sup>3</sup> )
TOTAL	3343 FT <sup>3</sup> (94.6 M <sup>3</sup> )	3605 FT <sup>3</sup> (102.0 M <sup>3</sup> )

G = GALLEY  
L = LAVATORY  
S = STOWAGE

**\*FOR MAXIMUM CARGO USAGE, ALL 737-200Cs  
USE THE WIDE-BODY-LOOK INTERIOR**



# 737-200C Cross Section

StartupBoeing

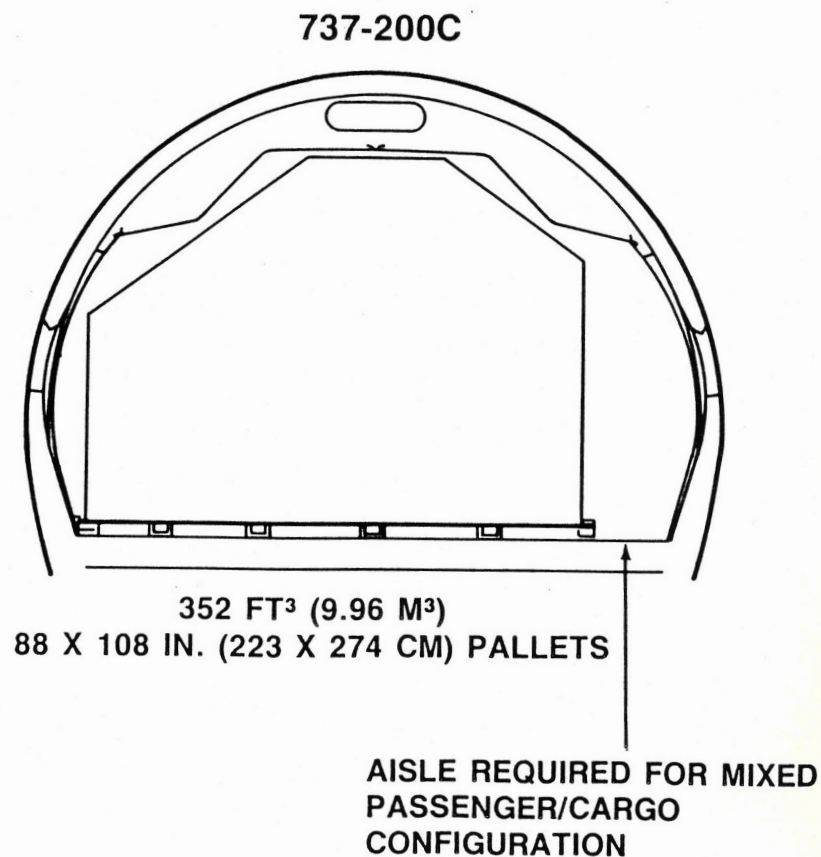
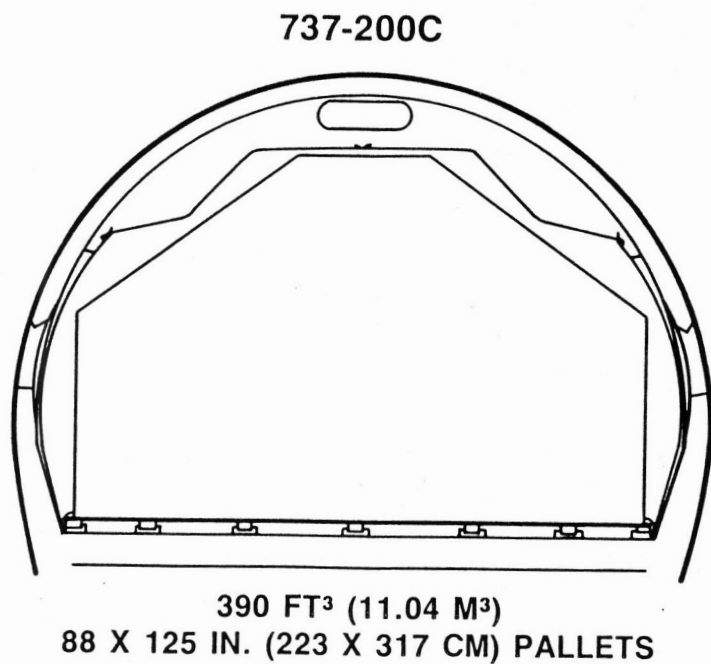

# 737-200 Characteristics

StartupBoeing

	BASIC AIRPLANE		AVAILABLE	
	ENGLISH	METRIC	ENGLISH	METRIC
<b>MAXIMUM DESIGN WEIGHTS</b>				
TAXI	116 000 LB	52 600 KG	TO 128 600 LB	TO 58 300 KG
TAKEOFF	115 500 LB	52 400 KG	TO 128 100 LB	TO 58 100 KG
LANDING	103 000 LB	46 700 KG	105/107 000 LB	47 600/48 500 KG
ZERO-FUEL				
PASSENGER	95 000 LB	43 100 KG		
CONVERTIBLE	95 000 LB	43 100 KG	96 500/99 000 LB	43 770/44 900 KG
<b>OPERATING EMPTY WEIGHT</b>	60 970 LB*	27 650 KG*	62 660 LB*	28 430 KG*
<b>FUEL CAPACITY</b>	5160 U.S. GAL.	19 530 L	5550 U.S. GAL. 5970 U.S. GAL.*	21 010 L 22 600 L*
<b>LOWER HOLD VOLUME</b>	875 FT <sup>3</sup>	24.8 M <sup>3</sup>	740/640 FT <sup>3</sup>	20.9/18.1 M <sup>3</sup>
<b>ENGINES</b>	JT8D-15A		JT8D-17A	
<b>PASSENGERS</b>	120 AT 32-INCH PITCH*		130 AT 30-INCH PITCH 110 AT 38/32-INCH PITCH	



# 737-200 Engine Characteristics

StartupBoeing

	BASIC	OPTION	ALSO AVAILABLE	
	JT8D-15A	JT8D-17A	JT8D-9A	JT8D-17AR
<b>TAKEOFF, SEA LEVEL STATIC THRUST</b>	15 500 LB 7030 KG	16 000 LB 7260 KG	14 500 LB 6580 KG	16 400 LB 7440 KG
<b>RESERVE THRUST</b>	-	-	-	17 400 LB 7890 KG
<b>FLAT RATING BYPASS RATIO</b>	84°F/29°C 1.08	84°F/29°C 1.05	84°F/29°C 1.04	77°F/25°C 1.00/.96
<b>MAX CRUISE, 30 000 FT, .80M, ISA NET THRUST</b>	4970 LB 2250 KG	5120 LB 2320 KG	4520 LB 2050 KG	5120 LB 2320 KG
<b>SPECIFIC FUEL CONSUMPTION, LB/HR/LB</b>	.786	.798	.802	.798
<b>ENGINE WEIGHT</b>	3474 LB 1576 KG	3475 LB 1576 KG	3377 LB 1532 KG	3500 LB 1588 KG

# 737-200 Payload-Range

StartupBoeing

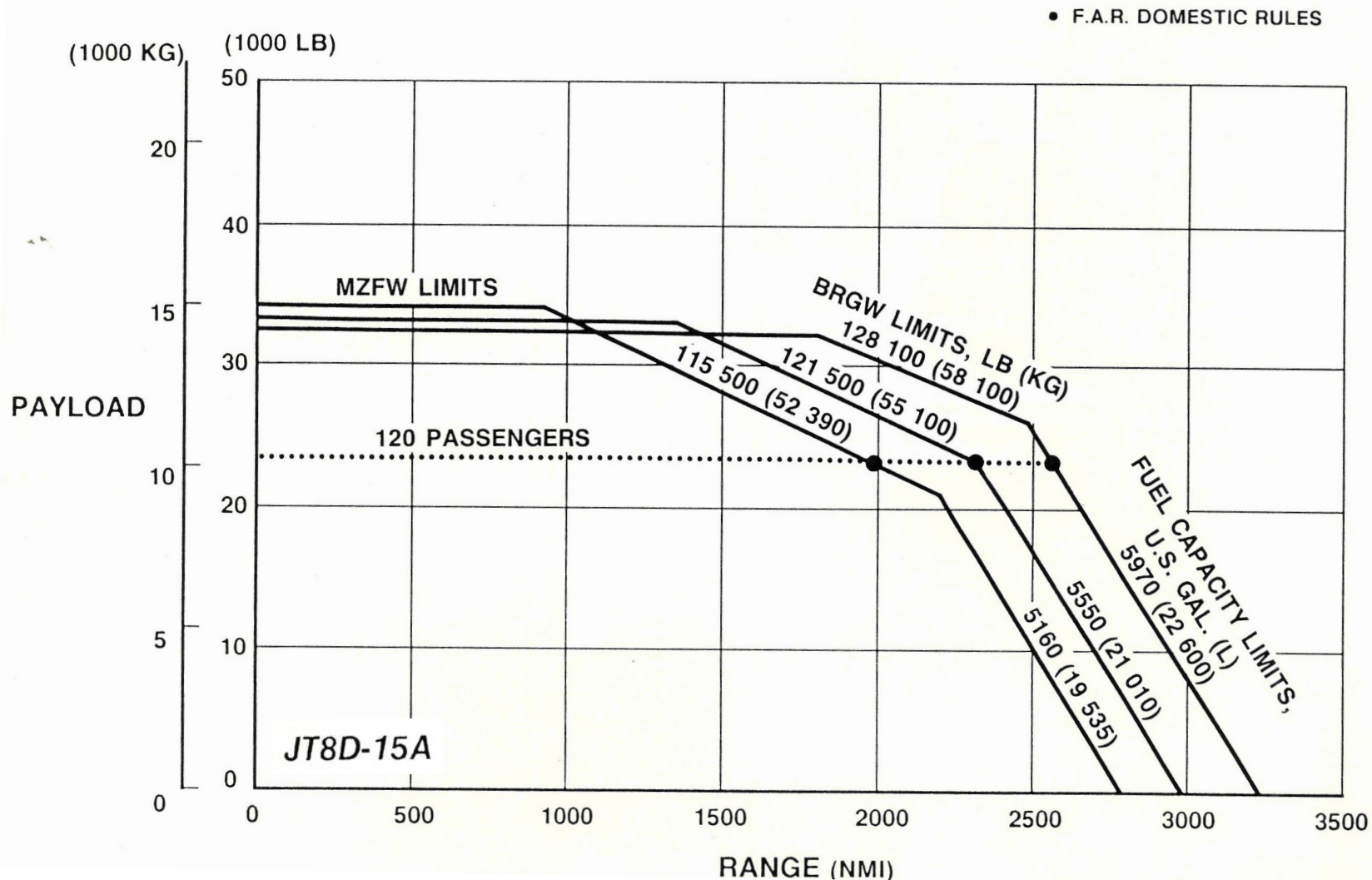



# 737-200 Flight Deck

StartupBoeing

