

DC-8

StartupBoeing



DC-8 Series General Arrangement

StartupBoeing

Model	Dimension (Ft)		
	A	B	C
DC-8-21 THROUGH DC-8-55	142.4	150.6	42.3
DC-8-61/-71	142.4	187.4	43.0
DC-8-62/-72	148.4	157.4	43.4
DC-8-63/-73	148.4	187.4	43.0

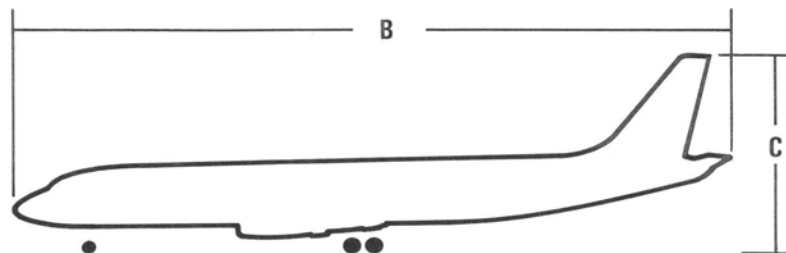
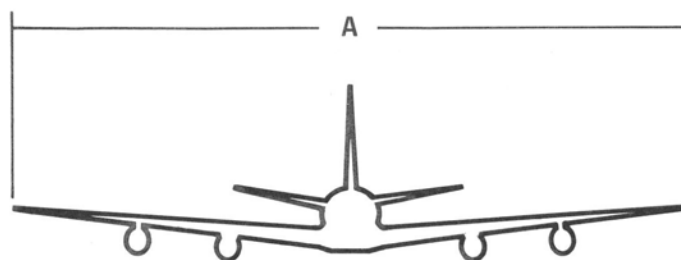
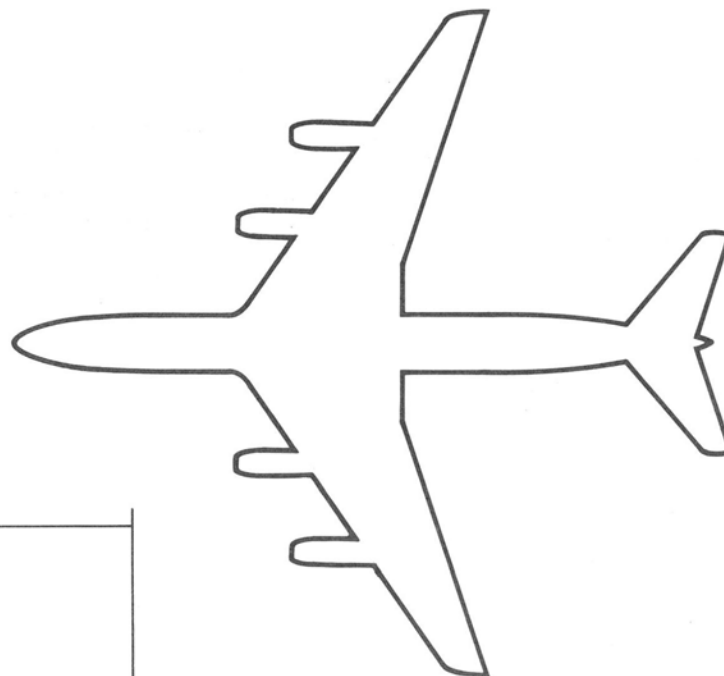

DC-8-20/-30/-40/-51/-52/-53 Interior Arrangements

StartupBoeing

MIXED CLASS
124 PASSENGERS

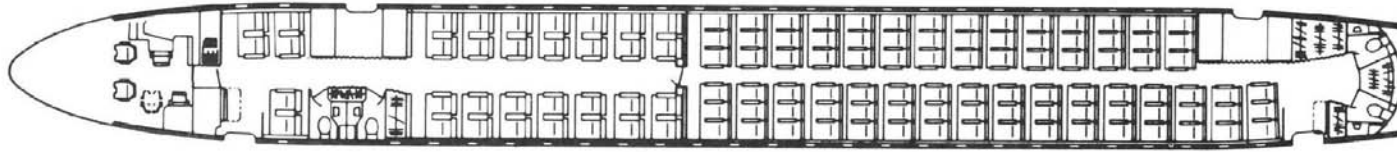

34 FIRST CLASS 40-IN. PITCH
90 COACH CLASS 38-IN. PITCH

ALL TOURIST
159 PASSENGERS

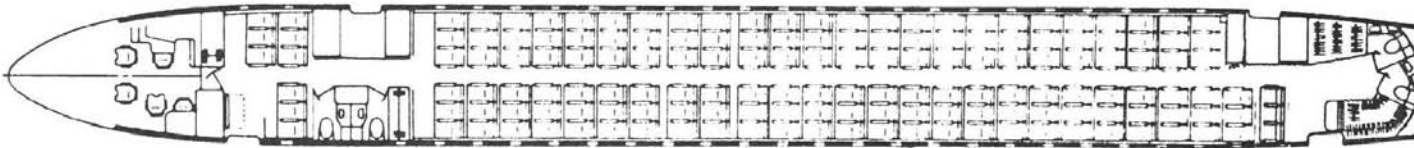

34-IN. PITCH

HIGH-DENSITY
177 PASSENGERS



31-IN. PITCH

DC-8-54/-55 Interior Arrangements

StartupBoeing

MIXED CLASS
144 PASSENGERS

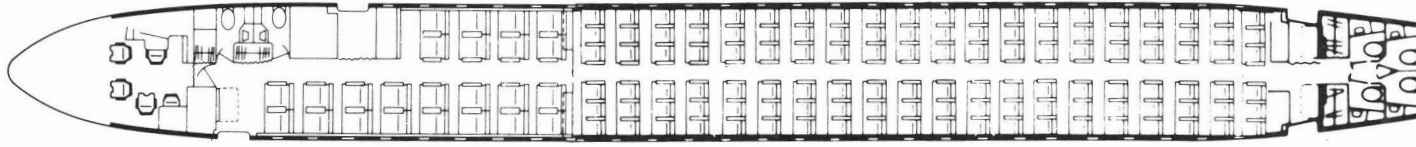

24 FIRST CLASS, 40-IN. PITCH
120 COACH CLASS, 36-IN. PITCH

ALL TOURIST
168 PASSENGERS

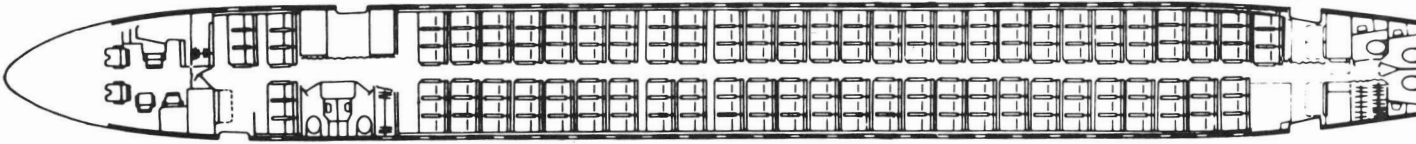

34-IN. PITCH

HIGH-DENSITY
189 PASSENGERS

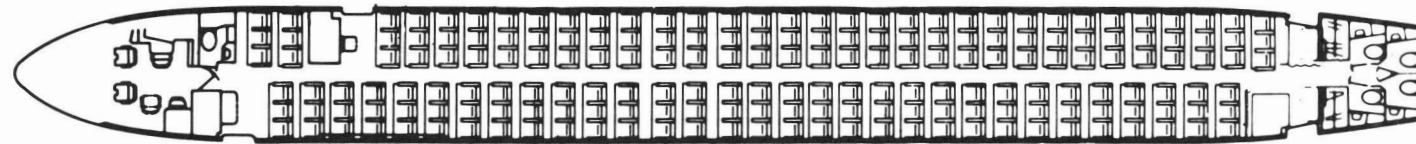

31-IN. PITCH

DC-8-54/-55 Convertible Freighter Arrangement

StartupBoeing

CARGO MODE



13 PALLETS, 88 IN. BY 108 IN.

MIXED PASSENGER AND CARGO MODE

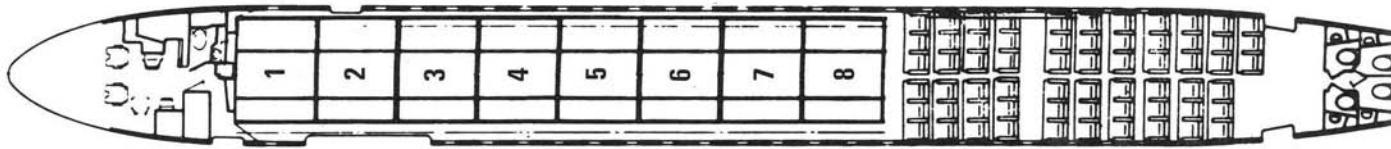

63 COACH CLASS, 34-IN. PITCH
8 PALLETS, 88 IN. BY 108 IN.

ALTERNATIVE
LOCATIONS FOR
CARGO BULKHEAD
POSSIBLE AT END
OF PALLET POSITIONS
3 THROUGH 12

DC-8-62/-72 Interior Arrangements

StartupBoeing

M.A.C. CONFIGURATION
170 Passengers

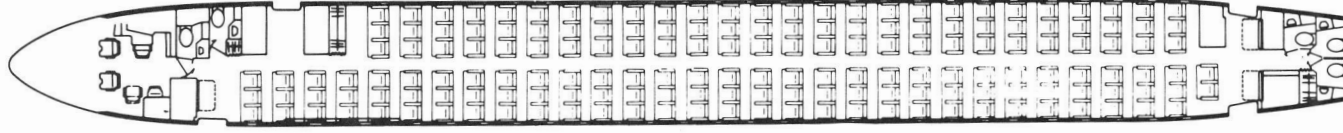

38-IN. PITCH

MIXED CLASS
162 Passengers

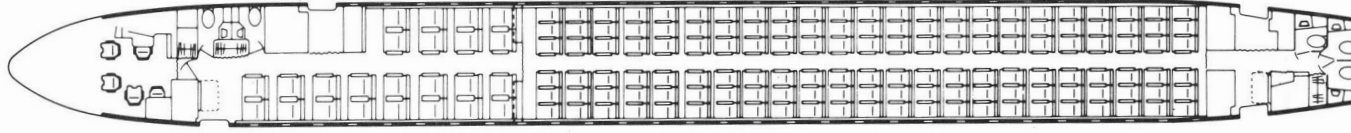

24 FIRST CLASS 41-IN. PITCH
138 COACH CLASS 34-IN. PITCH

ALL TOURIST
189 Passengers

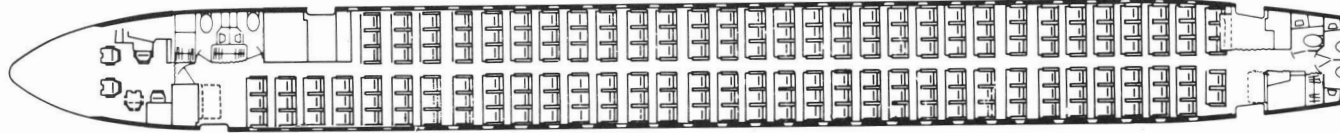

189 COACH CLASS 34-IN. PITCH
(+2 Seats for Flight Personnel)

DC-8-62/-72 Convertible Freighter Arrangement

StartupBoeing

ALL FREIGHTER

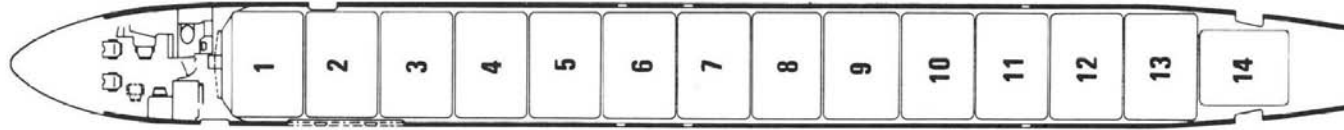

14 PALLETS, 88 IN. BY 125 IN.

MIXED PASSENGER AND CARGO MODE

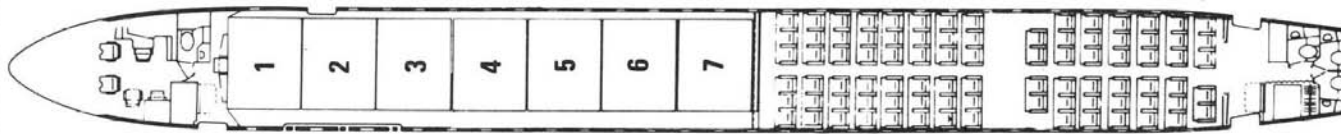

87 COACH CLASS, 34-IN. PITCH
7 PALLETS, 88 IN. BY 108 IN.

ALTERNATIVE
LOCATIONS FOR
CARGO BULKHEAD
POSSIBLE AT
END OF PALLET
POSITIONS 3
THROUGH 13

DC-8-61/-71 & -63/-73 Interior Arrangements

StartupBoeing

M.A. C. CONFIGURATION
218 PASSENGERS

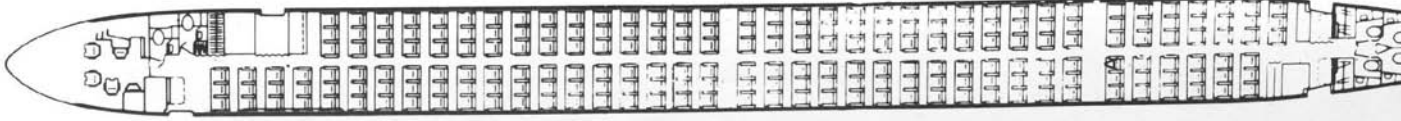

38-IN. PITCH

MIXED CLASS
209 PASSENGERS



34-IN. PITCH

ALL TOURIST
249 PASSENGERS



32-/34-IN. PITCH

HIGH-DENSITY
258 PASSENGERS

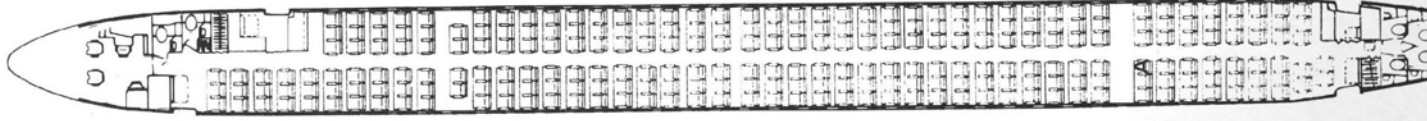

24 FIRST CLASS 37-IN. PITCH
186 COACH CLASS 34-IN. PITCH

DC-8-61/-71 & -63/-73 Convertible Freighter Arrangement

StartupBoeing

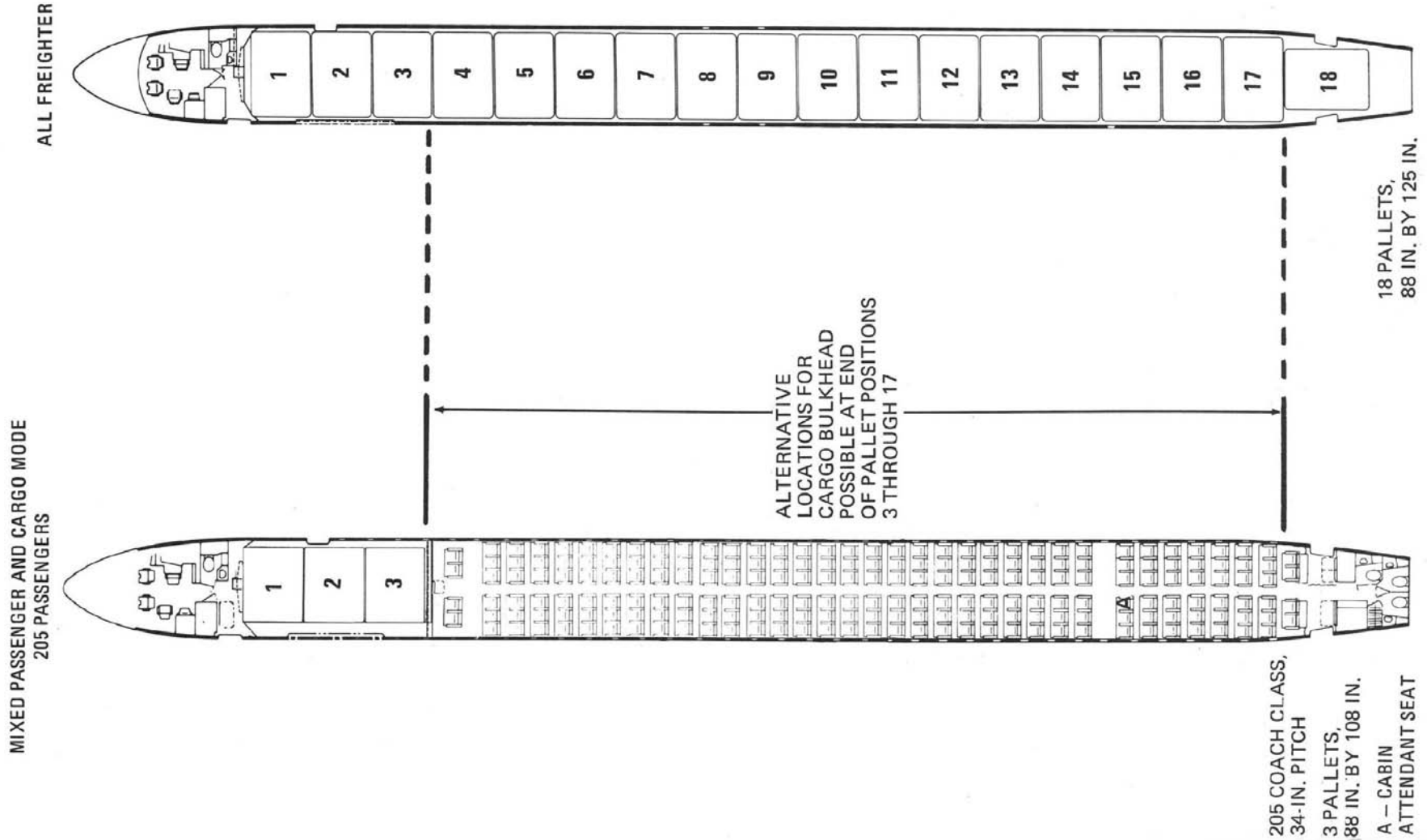

DC-8 Cross Section

StartupBoeing

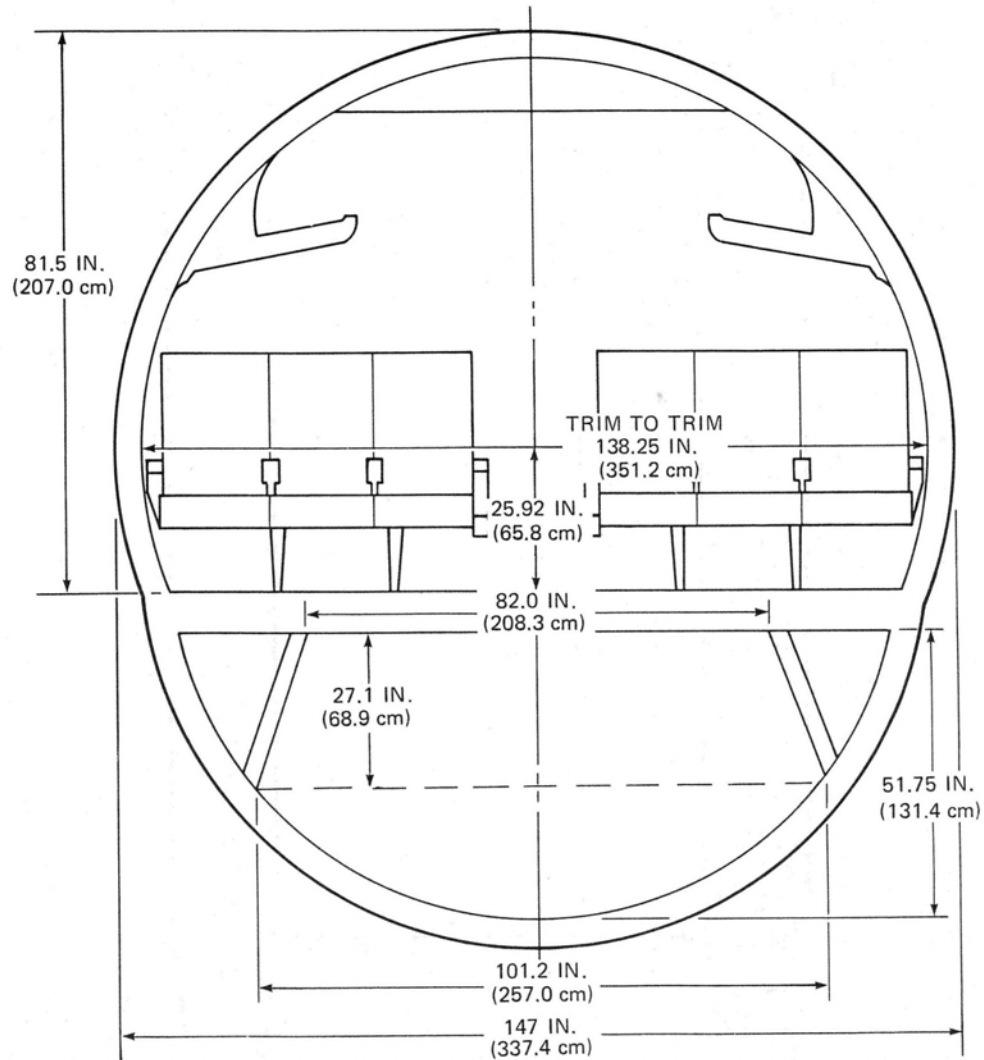

DC-8 Series Lower Hold

StartupBoeing

LOWER CARGO DOORS

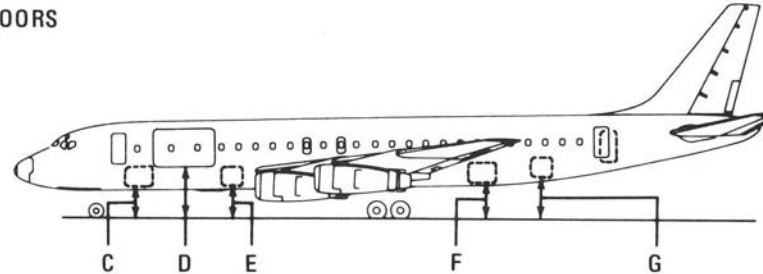

Model	Dimension (In.)													
	A		B		C		D		E		F		G	
	Max	Min	Max	Min	Max	Min	Max	Min	Max	Min	Max	Min		
DC-8F-54, 55	36	44	78.5	68.8	135.0	126.0	82.0	74.0	91.6	82.8	96.8	87.5		
DC-8-61CF	54	44	80.0	75.2	131.4	127.4	81.7	76.2	92.6	83.8	98.1	87.6		
DC-8-62AF, CF	54	44	77.3	73.3	131.6	127.6	80.3	74.9	93.7	83.2	100.0	88.1		
DC-8-63AF, CF, PF	54	44	80.6	75.6	131.5	127.8	82.2	76.7	91.5	84.3	98.4	88.0		

LOWER CARGO VOLUME

Aircraft Type	DC-8-21 Through DC-8-55	DC-8-61/-63	DC-8-62
Forward Compartment (Ft ³)	690	1290	800
Aft Compartment (Ft ³)	700	1210	815
Total (Ft ³)	1390	2500	1615

SERIES 70 DIMENSIONS AND VOLUME SAME AS 60 SERIES

DC-8 Series General Characteristics

StartupBoeing

Aircraft	Engines	Configuration	MTOGW (Lb)	MLW (Lb)	MZFW (Lb)	OEW (Lb)	Payload (Lb)	Fuel Capacity (Lb)
DC-8-21	JT4A-9	Basic Wing	276,000	199,500	167,500	137,000	30,500	119,360
DC-8-31	JT4A-9	Basic Wing	300,000	207,000	173,500	138,000	35,500	149,960
DC-8-32	JT4A-9	Basic Wing	310,000	199,500	176,500	138,000	38,500	149,790
DC-8-32	JT4A-10	1.5° D.F.*	310,000	207,000	178,400	139,000	39,400	156,705
DC-8-33	JT4A-12	1.5° D.F.*	315,000	207,000	179,000	139,000	40,000	156,705
DC-8-41	RCo-12	Basic Wing	300,000	207,000	173,200	138,000	35,200	149,830
DC-8-41	RCo-12	4% L.E. Ext.	300,000	207,000	173,200	138,000	35,200	150,050
DC-8-43	RCo-12	4% L.E. Ext.	315,000	207,000	178,200	139,000	39,200	159,065
DC-8-51	JT3D-1	Basic Wing	276,000	199,500	167,200	139,000	28,200	121,740
DC-8-51	JT3D-1		276,000	199,500	167,200	139,000	28,200	121,740
DC-8-51	JT3D-3B		276,000	199,500	167,200	139,000	28,200	121,740
			276,000	199,500	173,500	143,200	30,300	150,050
DC-8-52	JT3D-3B		300,000	207,000	183,500	136,100	47,400	121,740
			300,000	207,000	183,500	140,300	43,200	150,050
			300,000	207,000	183,500	141,650	41,850	159,065
DC-8-53	JT3D-3B		315,000	207,000	183,500	140,000	43,500	150,050
			315,000	207,000	183,500	141,350	42,150	159,065

NOTE: Starting with DC-8 Series 50, unless otherwise noted, a 4 percent leading edge extension is standard for all aircraft.

*D.F. - Drooped Flap

DC-8 Series General Characteristics

StartupBoeing

Aircraft	Engines	Configuration	MTOGW (Lb)	MLW (Lb)	MZFW (Lb)	OEW (Lb)	Payload (Lb)	Fuel Capacity (Lb)
DC-8-54	JT3D-3B		315,000	240,000	190,000	140,000	50,000	159,065
DC-8-54CF	JT3D-3B	Passenger	315,000	240,000	224,000	147,000	77,000	159,065
DC-8-54CF	JT3D-3B	Cargo	315,000	240,000	224,000	133,000	91,000	159,065
DC-8-54AF	JT3D-3B		315,000	240,000	224,000	128,000	96,000	121,740
			315,000	240,000	224,000	132,200	91,800	150,050
			315,000	240,000	224,000	133,500	90,450	159,065
DC-8-55	JT3D-3B		325,000	217,000	190,000	140,000	50,000	159,065
DC-8-55CF	JT3D-3B	Passenger	325,000	240,000	224,000	141,450	82,550	121,740
			325,000	240,000	224,000	147,000	77,000	159,065
DC-8-55CF	JT3D-3B	Cargo	325,000	240,000	224,000	127,450	96,550	121,740
			325,000	240,000	224,000	133,000	91,000	159,065
DC-8-55AF	JT3D-3B		325,000	240,000	224,000	128,000	96,000	159,065
DC-8-61	JT3D-3B		325,000	240,000	224,000	153,450	70,500	121,740
			325,000	240,000	224,000	157,650	66,350	150,050
			325,000	240,000	224,000	159,000	65,000	159,065
DC-8-61CF	JT3D-3B	Passenger	328,000	258,000	234,000	164,000	70,000	159,065
DC-8-61CF	JT3D-3B	Cargo	328,000	258,000	234,000	148,000	86,000	159,065
DC-8-62	JT3D-3B		335,000	240,000	195,000	149,000	46,000	162,529
DC-8-62	JT3D-7		350,000	240,000	195,000	149,000	46,000	162,529

DC-8 Series General Characteristics

StartupBoeing

Aircraft	Engines	Configuration	MTOGW (Lb)	MLW (Lb)	MZFW (Lb)	OEW (Lb)	Payload (Lb)	Fuel Capacity (Lb)
DC-8-62CF	JT 3D-3B	Passenger	335,000	250,000	230,000	154,000	76,000	162,529
DC-8-62CF	JT 3D-3B	Cargo	335,000	250,000	230,000	142,000	88,000	162,529
DC-8-62CF	JT 3D-7	Passenger	350,000	258,000	230,000	154,000	76,000	162,529
DC-8-62CF	JT 3D-7	Cargo	350,000	258,000	230,000	142,000	88,000	162,529
DC-8-62AF	JT 3D-3B		335,000	250,000	230,000	136,000	94,000	162,529
DC-8-62AF	JT 3D-7		335,000	250,000	230,000	136,000	94,000	162,529
DC-8-63	JT 3D-7		350,000	245,000	225,000	162,000	63,000	162,529
DC-8-63	JT 3D-7		355,000	258,000	230,000	162,000	68,000	162,529
DC-8-63CF	JT 3D-7	Passenger	355,000	275,000	261,000	168,000	93,000	162,529
DC-8-63CF	JT 3D-7	Cargo	355,000	275,000	261,000	152,000	109,000	162,529
DC-8-63PF	JT 3D-7		355,000	275,000	230,000	164,000	66,000	162,529
DC-8-63AF	JT 3D-7		355,000	275,000	261,000	145,000	116,000	162,529
DC-8-71	CFM56- 2		325,000	240,000	224,000	163,700	60,200	159,065
DC-8-71CF	CFM56- 2	Passenger	328,000	258,000	234,000	168,700	65,300	159,065
DC-8-71CF	CFM56- 2	Cargo	328,000	258,000	234,000	152,700	81,300	159,065
DC-8-72	CFM56- 2		335,000	240,000	195,000	153,200	41,800	162,529

DC-8 Series General Characteristics

StartupBoeing

Aircraft	Engines	Configuration	MTOGW (Lb)	MLW (Lb)	MZFW (Lb)	OEW (Lb)	Payload (Lb)	Fuel Capacity (Lb)
DC-8-72CF	CFM56-2	Passenger	350,000	250,000	230,000	158,200	71,800	162,529
DC-8-72CF	CFM56-2	Cargo	350,000	250,000	230,000	146,200	83,800	162,529
DC-8-72AF	CFM56-2		335,000	250,000	230,000	140,200	89,800	162,529
DC-8-73	CFM56-2		355,000	258,000	230,000	166,200	63,800	162,529
DC-8-73CF	CFM56-2	Passenger	355,000	275,000	261,000	172,200	88,800	162,529
DC-8-73CF	CFM56-2	Cargo	355,000	275,000	261,000	156,200	104,800	162,529
DC-8-73AF	CFM56-2		355,000	275,000	261,000	149,200	111,800	162,529