

# Innovation Quarterly

2016 November

## **A World Away**

Inspired by the human  
potential to go farther

## **Fun and Games**

Advanced learning

## **Training the Future**

The next generation  
of aerospace innovators

## Innovation Quarterly

### PUBLISHER

Greg Hyslop  
Boeing Chief Technology Officer

### ASSOCIATE PUBLISHER

Peter Hoffman  
VP Intellectual Property Management

### EXECUTIVE ADVISORY BOARD

Heidi Capozzi, Ted Colbert,  
Scott Fancher, John Hamilton,  
Dennis O'Donoghue, Jim Schlueter,  
Pat Shanahan, Charles Toups

### EDITOR

Candace Barron

### DEPUTY EDITOR

Will Wilson

### CONTRIBUTING EDITORS

Junu Kim, Tom Koehler,  
Daryl Stephenson

### GRAPHICS AND DESIGN EDITOR

Bill Crane

### DESIGN TEAM

Paula White, Lanette Fieser,  
Doug Yamada

### DIGITAL TEAM

Conan Kisor, Wendy Manning,  
Jim Newcomb

### BOEING TECHNICAL JOURNAL

John Adrian, Tim Bridges,  
Ken Hardman

### LEGAL ADVISOR

Tom Donahue

### COMMENTS

Comments and letters are welcome and may be published in subsequent editions. To submit a letter to the editor, email [candace.k.barron@boeing.com](mailto:candace.k.barron@boeing.com)

### WEBSITE

[boeing.com/IQ](http://boeing.com/IQ)

### ON THE COVER

Kauser Imtiaz is a structural analysis engineer and a Technical Fellow in Boeing's space vehicles group in Houston, Texas.

PHOTOGRAPHY BY ELIZABETH MORRELL

## Featured

### 6 | From the Moon to Mars

Inspired as a child in his native Pakistan, Kauser Imtiaz watched as man walked on the moon. Today the Houston-based Technical Fellow advises Boeing teams working on the International Space Station, Crew Space Transportation-100 Starliner and the Space Launch System, which could someday go to Mars.

### 12 | Cracking the code for space propulsion

Work in developing xenon-ion powered, all-electric propulsion technology for satellites wasn't easy, but it spurred a revolution in the way satellites are designed and built. It also earned Rich Aston, Glenn Caplin and Jim Peterka a 2016 Boeing Special Invention Award.

### 22 | A logical approach to learning

Boeing and NASA are pooling resources to face a common challenge: how to efficiently and thoroughly provide the next-generation of aerospace innovators with the skills needed to maintain technical leadership positions in the world. One step: an innovative small private online course for model-based systems engineering.

## Technical Papers

### 26 | Low-Cost Variable-Autonomy Ground Vehicles

While advancements are still needed in autonomous ground vehicle technology, particularly in regards to reliability, military applications are feasible today. Among the possible applications are autonomous supply vehicles and as casualty extraction vehicles in war zones, as ISR platforms with long range and endurance capability, as border patrol surveillance tools and even as assault vehicles capable of carrying a variety of armaments.

### 29 | Industrial Athlete

The Industrial Athlete program is an innovative, voluntary workplace program designed to improve the health and productivity of employees and address the need to keep employees strong and healthy. Multiple analytic techniques have been used to assess the effectiveness of the program given the challenges of implementing and sustaining it in a dynamic manufacturing environment.

### 32 | Checklists to Enhance Safety

Incorporating checklists in high-hazard environments can enhance safety—whether it is procedural, for preparation, or to solve problems. This paper examines the use of checklists in various environments, as well as human-factors studies that form the foundation for the use of checklists to improve safety.



# Lifelong learning, continuous development

This fall, Boeing recognized two important groups of employees: our 12 newest senior technical fellows and the winners of this year's Innovation Awards, presented to our best inventors and replicators. I congratulate all of these colleagues and thank them for their contributions.

As I think about these honorees, I realize that they prove an important point about Boeing: As our people become more capable, our products and services—and the processes we follow to make them—become more capable, too. That's why we place a special emphasis on learning and development. Our people must be ready today to address the challenges of tomorrow.

The pace of technological change will continue to accelerate. So it's imperative that we improve our technical and leadership skills, and know about breakthroughs that could either help or hurt our competitiveness. Development takes place in many ways, such as mentoring, seminars, rotational assignments and virtual activities. However, development happens only when each of us owns our careers and seeks opportunities to grow.

To maximize everyone's potential, we must continue to share our knowledge and fully embrace what a learning culture entails. Some people might view knowledge-sharing as a one-way street, where information flows only from veteran employees to new teammates. I strongly

disagree with this belief. I see knowledge sharing as a two-way street, because a true learning culture implies that we can gain knowledge from a variety of perspectives.

This work is important to Boeing's customers—and to the world. So, it makes sense to continuously develop our careers and support the development of our colleagues. That is how we will deliver for the billions of people who count on us and the work we do. **IQ**

### GREG HYSLOP

Boeing Chief Technology Officer  
and Senior Vice President of Engineering, Test & Technology

## Recognizing Advanced Developments and Research

# Technology RADAR

People working in Boeing's Technology Intelligence and Trends community of practice are human sensors in the world of science and technology. We make it our business to watch for innovations in practice, new business models and new ways of thinking. Here's a peek at a few signals on the screen.



### Roads that Harvest Energy

**LOCATION**  
Sacramento

**PROJECT URL**  
[energy.ca.gov](http://energy.ca.gov)

**MESSAGE**  
The California Energy Commission has approved a pilot program to install piezoelectric crystals on roadways in order to study the potential to harvest electrical discharges created when vehicles drive over the crystals.



### Self-Healing, Chemically Protective Clothes

**LOCATION**  
University Park

**PROJECT URL**  
[psu.edu](http://psu.edu)

**MESSAGE**  
By examining the properties of squid teeth, Penn State University engineers have developed a coating for clothing that patches its own holes and could also be used to protect against hazardous chemical exposure.



### Power from Tides

**LOCATION**  
Pentland Firth, Scotland

**PROJECT URL**  
[meygen.com](http://meygen.com)

**MESSAGE**  
The MeyGen tidal power project unveiled the first 1.5 megawatt underwater turbine for installation in the Pentland Firth, Scotland, where the project eventually aims to install enough turbines to power 175,000 homes with renewable energy.



### Chemically Grown UAVs

**LOCATION**  
Farnborough, UK

**PROJECT URL**  
[baesystems.com](http://baesystems.com)

**MESSAGE**  
University of Glasgow and BAE Systems researchers are collaborating to develop chemical processes that would "grow" aircraft and their electronic systems.



### Photo-Synthetic Fuel Cell

**LOCATION**  
Chicago

**PROJECT URL**  
[uic.edu](http://uic.edu)

**MESSAGE**  
Researchers at the University of Illinois at Chicago have developed a solar cell that converts carbon dioxide in the air into hydrocarbon fuel. Whereas photovoltaic cells convert sunlight into electricity in batteries, this cell acts like a plant, converting CO2 into synthetic gas, which can be burned directly or converted into hydrocarbon fuels.



### Cyborg Insects as Bio-Robotic Sensing Machines

**LOCATION**  
St. Louis

**PROJECT URL**  
[source.wustl.edu](http://source.wustl.edu)

**MESSAGE**  
Locusts' sense of smell could bolster bomb-sniffing capabilities for homeland security. Researchers at Washington University's School of Engineering & Applied Science are working to develop a bio-hybrid nose that replicates sophisticated biological chemical sensing systems.



### Solar-Powered Clean Drinking Water

**LOCATION**  
Abenta Village, Ghana

**PROJECT URL**  
[watly.co](http://watly.co)

**MESSAGE**  
Watly—a 15-ton, 130-foot long solar powered computer—can provide filtered drinking water, wireless internet access, and electronic device charging for up to 3,000 people daily. The device, created by a Spanish-Italian company, has been tested as a prototype in Ghana.



# A world away

**Watching humans set foot on the moon fixed an engineer's passion to go farther.**

BY DAN RALEY | PHOTOGRAPHY BY ELIZABETH MORRELL

Kauser Imtiaz was an impressionable teenager in 1969. Seated in front of a grainy, black-and-white, neighborhood television set in his native Pakistan, he watched with awe as humans set foot on the Moon for the first time.

He could barely make out the images on the screen—yet he sensed the moment had united the world. He was so inspired by this achievement of aerospace, Imtiaz decided then and there he would be a part of it.

"I still remember many elders were in disbelief, saying, 'This is hoax; it is impossible,'" Imtiaz recalled. "But hearing that man had landed on the moon, the young ones were excited. We were dancing. Earth seemed to be a very small and happy place."

Imtiaz had even greater incentive to realize this dream once those same American astronauts came through Pakistan on a triumphant world tour. He got to see a piece of lunar rock that went on display at a museum in Karachi.

Immediately following his high school graduation, Imtiaz left for the United States to pursue an education in aerospace. Naturally curious, he was determined to immerse himself in life-changing events, as well.

"You never know what you'll find when you look into the unknown," he said.

Today, Imtiaz is an American citizen and a Houston-based Boeing Technical Fellow, a structural engineer tasked with

unraveling complex issues that surround the International Space Station and manned space flight.

He advises Boeing teams working on the Crew Space Transportation-100 Starliner, expected to provide continuous manned flights to the International Space Station, and the Space Launch System, which could ferry people to Mars.

"He's pretty much our go-to guy when we have a really challenging issue," said Deneen Taylor, NASA manager for International Space Station structural engineering.

"He's not just an all-around nice guy, he's brilliant and he's always willing to step in and help out. He's never denied us when we've asked for his help. He's always been willing to do what it takes," Taylor added.

During an assembly analysis, for example, Imtiaz found structural weakness near berthing ports that connected all of the Space Station modules together. Working challenging hours, he and his team provided a solution that prevented a costly redesign and a lengthy program delay, according to David McCann, Boeing senior manager of space structures and flight-control mechanisms, and a former NASA structural engineer.

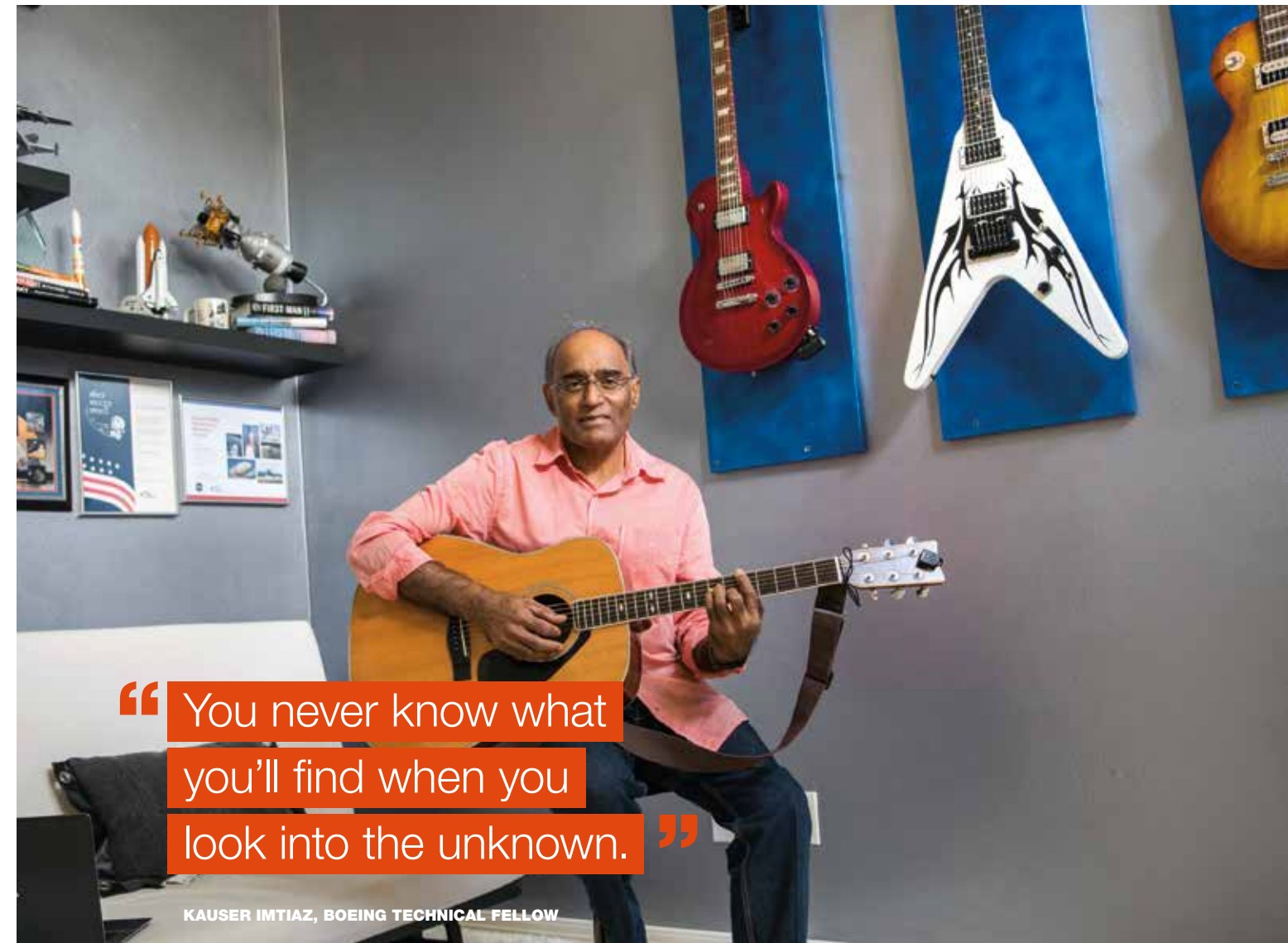

“You never know what you’ll find when you look into the unknown.”

KAUSER IMTIAZ, BOEING TECHNICAL FELLOW

"It was very much a showstopper kind of failure of basic structural design," McCann said. "Kauser led a team that did all of the analysis, modeling and testing to determine the best way to fix the problem—which turned out to be kind of elegant and amazing, and saved a lot of work not to redesign the whole interface."

From then on, Imtiaz and the Space Station have been invariably linked. He claims to know every inch of the massive spacecraft, which is similar in size to a regulation football field. He welcomes the pressure of keeping it structurally sound at all times.

"The more challenge I get, the better I get," Imtiaz said. "My productivity shoots up when I'm under stress. My thinking gets faster. I don't get panicked or get concerned; I just focus and I get things done. I enjoy that."

On another occasion, a solar panel came unhinged on the orbiting Space Station, creating a precarious situation. Imtiaz produced a fix that he tested on a duplicate solar panel on the ground. A step-by-step solution was sketched out and sent to the astronauts on board—cut a pair of holes in the sheet metal and braid electrical wire through them to create what resembled large cufflinks. U.S. astronaut Scott Parazynski performed the delicate repair during a spacewalk, using an insulated stick to tie the torn panel and prevent electrical shock.

Out of gratitude, Parazynski gave Imtiaz a keepsake—a piece of red ribbon he wore around his leg that distinguished him from other spacewalkers.

"We saved the solar panel," Imtiaz said. "We didn't have to jettison it and launch a new one."



### COOL UNDER PRESSURE

A Boeing team discusses the Common Berthing Mechanism, the interface between ISS pressurized modules, at NASA Johnson Space Center in Houston. From left, David McCann; Kauser Imtiaz; Carter Reznik, mechanical engineer; and Jawaid Mansury, structural engineer.



Imtiaz also created a unique software tool that analyzes the Space Station's 10,000 structural joints. It reduces 10-12 hours of work to 10 minutes or less. It has saved millions of dollars, according to program managers.

This software goes a long way in predicting fatigue and failure. People throughout NASA and Boeing have grown to depend on it, McCann said.

Users became so trusting of Imtiaz's software tool, "we floated it out to other areas and use it on other space vehicles," McCann explained. "It's really had a big impact on the space industry for manned space flight. He keeps improving it."

As he planned, Imtiaz was educated in the United States, earning an aeronautical engineering degree from St. Louis University, and his masters in aerospace from Wichita State University. He obtained a private pilot's license and an FAA airframe and power plant mechanics license.

Imtiaz came to Boeing in 1987, joining the C-17 Globemaster III program in Long Beach, California. He previously worked as an aircraft engineer for the Saudi Royal Fleet in Jeddah, Saudi Arabia, and for Beech Aircraft in Wichita, Kansas. He later worked on Boeing helicopters in Arizona and Pennsylvania.

This journey brought him to the International Space Station program and Huntsville, Alabama, in 1991. It was what he envisioned more than two decades before—when that neighborhood TV set took him to the moon and back.

"The pride of my work is working on the manned space program," Imtiaz said.

He has plenty to keep him busy. The Space Station was designed to be in use for 15 years, but the robust spacecraft is re-certified structurally through 2028—which would make it operational for 30 years. Imtiaz shares in the different phases of life-extension analysis for the Space Station, and in testing in which they "excite" the structure in space to see how it responds.

While space keeps a firm hold on him, Imtiaz is similarly well defined by his wide range of personal interests and hobbies. He is deeply involved in Pakistani and Indian music, which he describes as "East-West fusion." He plays keyboards, guitars and several other instruments. He has a studio in his home. He has played in different public venues, among them a Houston hotel in front 1,000-plus people and a half-dozen universities.

He's also a dedicated photographer, shooting natural light,

"I get into everything, from appliances to my cars to my electronics. I just feel I have to figure things out and to learn and to fix things, or at least try."

KAUSER IMTIAZ

nighttime and airshow images. He writes poetry and reads and collects books.

And he acts as an engineer at all times.

"I get into everything, from appliances to my cars to my electronics," Imtiaz said. "I just feel I have to figure things out and to learn and to fix things, or at least try."

Imtiaz has traveled the world exclusively to discuss the latest space developments, most frequently to Russia, Italy, Germany and Japan.

He has met and worked with several American astronauts, among them John Young, who walked and drove a lunar buggy on the Moon, and presented Imtiaz with a NASA commendation. He's encountered foreign leaders and ambassadors, too, but it's not quite the same—they didn't leave their footprints in lunar dust.

Imtiaz said he feels compelled to share what he's learned with the coming generations. He has created numerous courses and video classes. He's a lecturer and mentor to Boeing colleagues, a teacher to elementary- and middle-school students.

And yet, Imtiaz is still learning. He remains fascinated by the Big Bang Theory, ever curious of how the universe was created. He reads everything he can about the subject. He studies the work done by others. He is encouraged that bigger and better telescopes coming on line could someday lead to an answer.

He is not done with watching people walk on the Moon, either. He wants to see it happen again. This particular achievement lured him into the aerospace world and eventually to Boeing and human space travel. He can't think of a better way to finish his career than to revisit the Moon, which would help promote travel to Mars.

"The final chapter in my life would be to continue with NASA's vision of building a Space Station in a lunar

neighborhood," Imtiaz said. "We could use an Earth and Moon Lagrangian point (neutral gravity) and go down and build a basecamp on the Moon. That would be full circle. That would wrap things up. What a journey this has been." 

### POWERED UP

David McCann and Kauser Imtiaz talk Solar Array Rotary Joint operations at NASA Johnson Space Center in Houston.





TECHNICAL EXCELLENCE. **ENGINEERING ACHIEVEMENT.**

# Congratulations.

## Our 2016 Innovation Award Winners



### Special Invention **Awards**

are determined on the basis of technical innovation, degree of implementation, internal business value to Boeing, business value to customers, and licensing value to Boeing.

Richard Aston  
Glenn Caplin  
James Chen  
Angelia Corbett  
Walter Frantz  
Joseph Gallegos

Paul Gehlsen  
Kim Griffin  
Hisashi Inoue  
John Jones  
Haig Krikorian  
Douglas Maben  
Albert Manfredi

Scott Meier  
David Otto  
Jayant Patel  
James Peterka III  
Matthias Schriever  
Louie Tran

### Technical Replication **Awards**

highlight the most successful projects where cross-enterprise collaboration, learning and replication have driven productivity, growth and program execution.

James Badman  
Brittany Ballard  
Michael Clare  
Joshua Crouch  
Christine Currie  
W. Talion Edwards  
Edward Feikert  
Ronald Goodman  
Sankeerth Goli

Steven Gunther  
Thomas Howorth  
John Inman  
Lindsay Jones  
Timothy Josten  
Mark Leach  
Eugene Lowe  
Brian Malin  
Dennis Mathis

James Muir  
Mark Schergen  
Neil Shah  
Kevin Sitton  
Nicholas Sophy  
Steven Strouse  
Terry Versheldon  
Patrick Walsh  
Kim Wood

# Inventing our future

**How one team pushed the boundaries of innovation and cracked the code for advanced space propulsion.**

BY JILL HULINGS | PHOTOGRAPHY BY SALLY ARISTEI

## READY TO LAUNCH

Senior Technical Fellow Rich Aston (left) explains to Peter Hoffman, Boeing's vice president of Intellectual Property Management, the novel structural improvements that were made to allow satellites to be vertically stacked and launched in pairs.



Nearly 60 years ago, Sputnik 1, the world's first artificial satellite—a heavy, metal sphere the size of a beach ball—was launched into orbit with highly explosive rocket fuel.

And in the decades since, larger, more powerful satellites have used these fuels as a source of power. Engineers had dabbled with safer, cleaner ways to maneuver their spacecraft, but no one ever kicked the chemical habit.

That is until last year, when Boeing engineers successfully deployed a pair of satellites, the 702SP, featuring patented xenon ion powered, all-electric propulsion, stacked one atop the other, into geosynchronous orbit.

Not only did Boeing's technology work, it revolutionized the way the industry designs and manufactures satellites on a global scale. Another pair was launched earlier this year.

In particular, the 702SP team implemented all of 15 developments needed to fly and prove out this new design in less than four years, when comparable systems have taken closer to six or seven years to deploy. This timeline has yet to be met in the industry, and the competition is still working to match this level of performance.

For this advancement in the state of the art, Boeing has awarded the inventors of this propulsion system its Special Invention Award, which annually honors innovators for technological achievements in aerospace.

Pioneering this new technology was no easy feat for inventors Jim Peterka, Glenn Caplin and Rich Aston. When the project began nearly five years ago, everyone knew that satellites required at least a little bit of chemical fuel to create the kind of thrust satellites needed. Ion space

SOURCE: BOEING

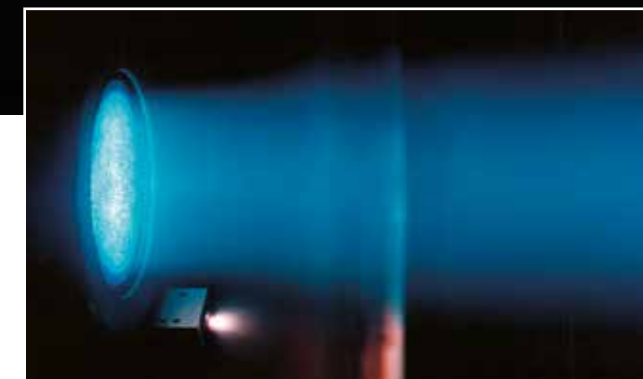
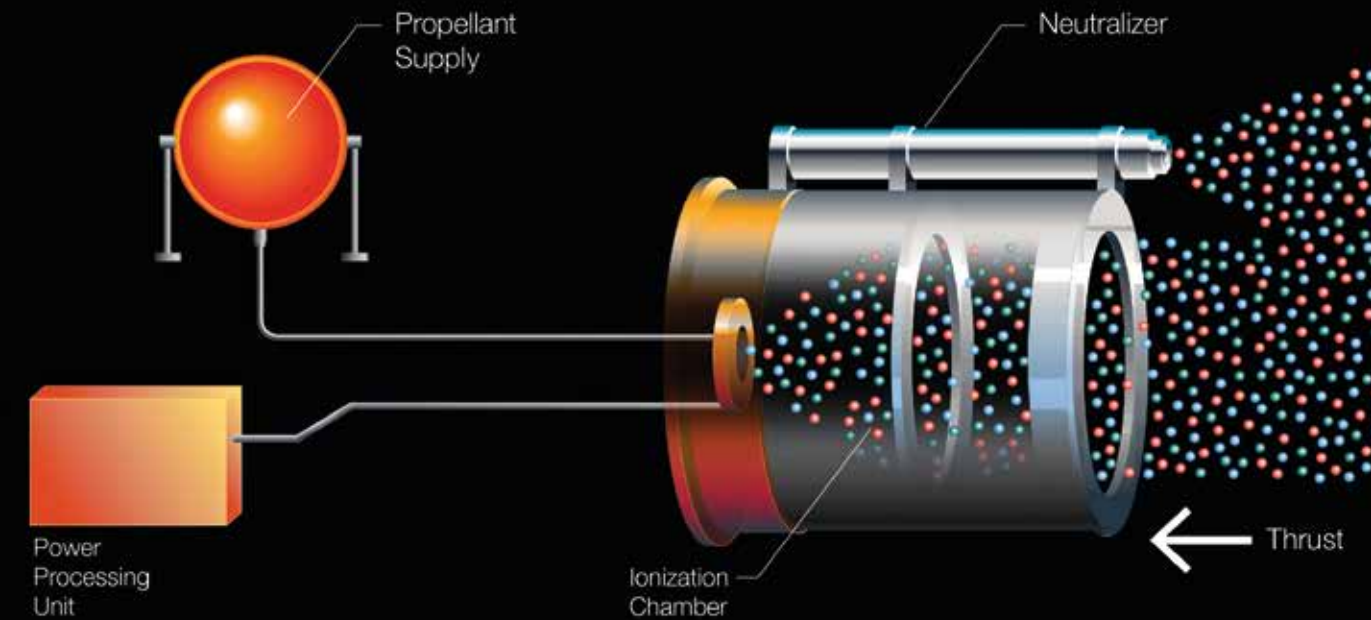

## HOW IT WORKS

Thrust is created by accelerating the positive ions through a series of gridded electrodes at one end of the thrust chamber. The electrodes, known as an ion extraction assembly, create more than 11,000 tiny beams of thrust. The beams are prevented from being electrically attracted back to the thruster by an external electron-emitting device called a neutralizer. Ions ejected by the XIPS engine travel in a stream at a speed of 30 kilometers per second (62,900 miles per hour), nearly 10 times that of its chemical counterpart. Photo at left, aided by special lights, is an ion thrust beam from the first 13-centimeter XIPS qualification thruster.

propulsion had been studied for decades, but little was known about how the spacecraft would react to using all-ion propulsion. And what if something went wrong once the satellite was in orbit? Repairs are extremely difficult to make once the product is in space. These were the risks the team took, and they paid off.

Because it doesn't carry the heavy fuel and bulky chemical thruster, the 702SP has a significantly reduced mass compared to its predecessors, Aston explained. This helps allow a rocket that would only be able to fit and carry one satellite to carry two.

"We cracked the code for controlling satellites by taking a risk with the removal of chemical propulsion," Peterka said. "We knew there might be a downside, but you have to take risks. As long as we found the winning solution, and applied the right people, we knew we could win and stay ahead of the competition."

The Xenon Ion Propulsion System, or XIPS, uses the impulse generated by a thruster ejecting electrically charged particles at high velocities. Rigorous testing showed that solar panels could generate the electricity needed to ionize and accelerate the xenon gas. The spacecraft's propulsion system contains a sufficient quantity of xenon to extend the satellite's operations beyond the expected spacecraft design life of 15 years, according to data from Boeing Satellite Systems International.

"It's been commercialized into our products," Aston said. "We're gaining market share, gaining a competitive advantage and it's being replicated by our competitors."

Tell anyone on the street you work in satellites and you're bound to get a lot of questions.

"It's not a normal job, so people are curious," said Aston, a Boeing Senior Technical Fellow. "There's a really cool,



**A MENTOR INVENTOR**

Rich Aston confers with Anna Tomzynska, his co-inventor and protégé, on multiple improvements to the 702SP satellite system.



“It’s not a normal job, so people are curious.”

**RICH ASTON,  
BOEING SENIOR  
TECHNICAL FELLOW**

cutting edge aspect of the satellite technology that not many people understand.”

Aston recalls the many mentors he encountered as a young engineer at Boeing. His fondest memories were his conversations with veteran technologists who began their careers at Douglas Aircraft Company and helped design fighter jets like the Douglas A-4 Skyhawk.

“They took me under their wing and taught me how to design correctly using materials and fabrication,” he said. “I was very fortunate to learn from these engineers.”

This early exposure to mentorship continues to influence his work philosophy today. Aston says he makes every effort to pay it forward by mentoring younger, up-and-coming engineers, like Anna Tomzynska.

Tomzynska was provided many opportunities to flex her mental muscles on technically challenging projects during her 13-year mentorship with Aston. For example, the two were co-inventors on several new technologies included in the 702SP launch, which landed her a previous Boeing Special Invention Award.

“Anyone who has worked with Rich can attest that he inspires others to achieve their best. He often reminds me

to make sure I’m constantly learning in whatever endeavors I pursue,” she said.

Relishing his achievement, Peterka, program manager for the 702 product line for Boeing Commercial Satellite Systems, said it all began with an early fascination of space and the unknown. Peterka began his career as a Boeing engineer in the 80s, and began tinkering on high performance satellites in the 90s. As a child who came of age during the space race and “2001: A Space Odyssey,” he was enthralled with outer space and anything that could expand human knowledge of it. His father and uncle, both engineers, also encouraged his love of space and science.

“My uncle worked for Northrop and was part of the great wave of inventors back in the 60s,” Peterka said. “We talked a lot about technology and science. I knew engineering was a career that would allow me to learn something new every day.”

Tomorrow’s innovators should also remember that inventing isn’t easy, Aston added. “If you choose innovation and inventing, you have to be tenacious. You have to be willing to withstand a few failures. If it were easy, the other guys would be doing it.” **IQ**



**CANDICE SMITH,  
DIRECTOR  
OF GLOBAL  
ENGINEERING**

To compete, win and deliver aerospace innovation over the next 100 years, Boeing will rely on and be driven by a diverse, multi-skilled technical workforce that has a truly global mindset and can rapidly adapt to meet operational needs.

But how can we ready this diverse talent pipeline quickly and more effectively?

The answer is to move beyond traditional models of educating and training generations of technical thinkers and doers. Championing advanced learning approaches and methods will take full advantage of our world-class technical community, achieve our STEM goals with the future workforce, and drive long-term business success.

**Training and development needs to:**

- Accelerate and be individualized for each learner.
- Be responsive to emergent needs.
- Be collaborative via a social component.
- Take advantage of new platforms such as online courses, hackathons, tech-based competitions and innovation challenges.
- Offer continuous improvement of teaching techniques in response to research on how people learn.

## A culture of learning

**Adopting new models to enable the knowledge and experience needed to solve the world’s toughest problems.**

- Deliver “just-in-time” development and training capabilities to arm people with actionable knowledge when they need it.

A traditional education model of facts and formulas is significant to understanding the foundational principles of science, engineering and problem-solving; however, proof of applying these principles to solve real problems or learning how to approach a solution is increasingly more important.

**Building a strong and diverse early-career pipeline requires that students are better prepared to join our ranks.**

They do so as we evolve to accelerate innovation much earlier in the life cycle of our products and services.

That’s why it’s important for Boeing to partner with educational institutions and external technical affiliates to share the capabilities and skills we expect our workforce to possess. We also have an opportunity to develop organic learning opportunities with our internal experts.

As we invite students to join us as interns, we must offer them a chance to complement their experience-based learning with advanced learning opportunities that broaden their perspective. Encouraging them to get

involved with experienced colleagues increases their pace of learning and confidence in applying learning to their projects, and promotes a culture of innovation early on.

Just as importantly, these advanced learning principles and approaches provide our current workforce opportunities to learn and apply new skills quickly, enabling those in mid-career to take full advantage of their experience and enterprise knowledge. This will also be a great advantage for our business, as we will be able to train and deploy skilled workers to target emergent functional and technical needs.

Those who are nearing retirement or are later in their careers should also be key contributors to our advanced learning strategy, as rapid and responsive training techniques can help connect just-in-time knowledge with hands-on learning. With advanced methods, our most experienced talent will have more effective ways to teach others in their accumulated expertise.

With the right strategy, culture, tools and tactics, we can bolster the skills of our global workforce, helping them more rapidly develop and apply new skills. We will learn quickly from successful and unsuccessful outcomes, then apply those lessons to produce the best quality, most valuable products and services. **IQ**



# Brandt Dargue

## talks advanced learning



**Technologies including simulations, adaptive scenarios, intelligent tutoring, cognitive science and gaming concepts help create more effective and efficient learning experiences.**

BY WILL WILSON | PHOTOGRAPHY BY ERIC SHINDELBOWER

**Q&A** with an associate technical fellow doing research in advanced training concepts

**Q** Are you promoting fun and games at work?

**A** I research how to make training better. And I'm saying that we learn better—more productively and with higher quality retention and later application—when we learn through having fun.

Games have been used for teaching for thousands of years. For example, the games Chess and Go were actually created to teach battle strategies. The term “serious game” was coined to represent games that are designed for a purpose other than entertainment.

The customers for my team's research include instructors, instructional designers, training developers and simulator developers. They see how much more motivated and engaged their students are in games than in class. So my customers asked me to find out how to incorporate elements of games into their training or training devices. I began by examining the vast research into serious games and merging instructional design principles with game design.

**Q** How would you describe advanced learning?

**A** Advanced learning is simply using research, science and technology to make training and other learning experiences better—more effective, memorable, relevant and enjoyable.

The history of human learning is as old as the history of humans. Written theories on how people learn and how to make the learning experience

#### **FUN AND GAMES**

Associate Technical Fellow  
Brandt Dargue in his St. Louis lab.

“Enabling these flow conditions has been the goal of our advanced learning research.”

BRANDT DARGUE



better go back at least to Socrates. The ability to monitor the brain in real-time through electroencephalogram (EEG) and functional magnetic resonance imaging (fMRI) have allowed us to see that most learning theories were correct, but a little too narrow.

An epiphany came to me from studying more about goals, optimal performance, and the theory of the psychology of flow: The reason why games are fun is that the players actually learn while playing.

Scientific research of games shows players are motivated to play because the game provides an environment in which the players learn and improve. In other words, games are fun because players learn. Humans, and possibly other animals, are genetically programmed to get pleasure from learning. Once you have stopped learning from Tic-Tac-Toe, it is no longer fun. When someone learns all they want from Chess and stops improving, the game is no longer fun. Those who feel they can still get better and learn from playing find the game fun for many years.

Instead of a mindset that students of all ages do not learn because classes are boring, we should realize that classes and training are boring when there is little opportunity for students to learn.

**Q What makes training most effective?**

**A** Research suggests that people are happiest when performing at their peak. They describe a state of ultimate performance as being “in the flow.” Mihaly Csikszentmihályi (a psychologist known for his work on happiness, creativity and flow theory) discovered that there are several conditions of flow: the person is actively involved in a task with clear goals; progress toward goal can be measured and the person

receives immediate feedback on the progress; and the perceived skills required for the task are aligned with perceived abilities—I’m trying to achieve something difficult; I think I know how to get there; and I believe with more work, I can.

In Steven Kotler’s 2014 book, “The Rise of Superman: Decoding the Science of Ultimate Human Performance,” he states that frequent flow experiences can “shorten the learning curve.” This is evidenced by studies, such as one in 2011 by DARPA, in which flow reduced the amount of time to teach novices to become experts by 50 percent.

**Q What remains hardest when it comes to learning and teaching?**

**A** Despite extensive research, training to overcome cognitive biases has proven largely ineffective. Critical decision-making in the face of uncertainty is difficult because participants employ heuristics that are unconscious and subtle, but which can produce very serious impacts. It has often been demonstrated that even cognitive bias experts make judgment errors by falling prey to the very biases they study.

But we are making headway. My team at Boeing designed and developed a video game, “The Enemy of Reason,” to teach cognitive bias recognition and mitigation as an alternative to current multi-semester classroom methods. U.S. government assessments indicated that our game was effective for learning to recognize and mitigate the effects of bias. In particular, eight weeks after learning, students who learned using the game were able to recall and apply the knowledge better than those who had not. **IQ**



KEVIN WISE,  
SENIOR TECHNICAL  
FELLOW

## Ready, set, learn

**Success in a global competition will come to those who develop talent, techniques and tools so advanced that they essentially have no competition.**

Change comes at a rapid pace.

We can see on the horizon a new age of autonomous systems for which opportunities are endless: Self driving cars and trucks, autonomous package and cargo delivery systems, medical diagnostics and operating room robotics.

Autonomous systems with machine reasoning and intelligence will change forever how machines serve humans. Humans and machines will both understand mission context, sharing understanding and situational awareness, and adapt to the needs and capabilities of each other. Sensor networks will provide unprecedented safety, reliability, communication and performance.

For our workforce to compete and be successful in the future, it will need to learn fast to keep up. Our success will be fueled by our ability to learn new technology skills, new applications, and new ways to conceive of problem-solving in light of machine learning and autonomy.

So how will we teach our new generation of engineers? Many Boeing technical fellows are engaged in teaching post-graduate level courses at colleges and universities.

I have the privilege of teaching graduate level control theory at Washington University in St. Louis, home to one of the National Academy of

Engineering’s Grand Challenge schools. These are colleges committed to educating a new generation of engineers expressly equipped to tackle some of the most pressing issues facing society in the 21st century.

Control theory brings together advanced mathematics, modeling and simulation, software development, and forms the kernel for the operating systems embedded within an autonomous system.

I use some of the most recent and challenging aerospace problems in my courses. They teach engineers how far technology has come, how far it needs to go, and what skills will be needed in the future. Our recent text book on robust and adaptive control theory is in the top three best sellers for the publisher. It captures the most useful and successful control theories used in aerospace, and builds upon them to create adaptive system theory needed for future self-learning autonomous systems.

One of the most significant challenges in autonomous system development is dealing with failures, damage, or when things go wrong. This is called contingency management. It is impossible (and cost prohibitive) to program conventional If-Then-Else control logic for every possible scenario. Our method uses model reference adaptive control, in which a reference model is used to model and produce

healthy system behaviors. During a contingency event, if the system differs from the model’s response, a neural-based nonlinear control algorithm forces the system to behave like the model, providing both stability and performance. Our algorithms don’t need to know what went wrong, which makes the design robust. They are deterministic, repeatable and testable, which is critical for Boeing products.

All of our early career engineers who work in flight control take my courses, which are now being taught at Boeing for credit and can use real Boeing challenges to teach and demonstrate the theory. This advanced learning solidifies the use of fundamentals, and accelerates our engineers’ skill development to make them ready for our future challenges.

Preparing our engineering workforce for the future is one of the most important duties for an industry leader like Boeing. Our engineers are eager to run in this technology race. The excitement they bring will make the world a better place over the next 100 years. **IQ**

Kevin Wise is a Boeing senior technical fellow for flight control technology and fellow of the American Institute of Aeronautics and Astronautics and the Institute of Electrical and Electronics Engineers.



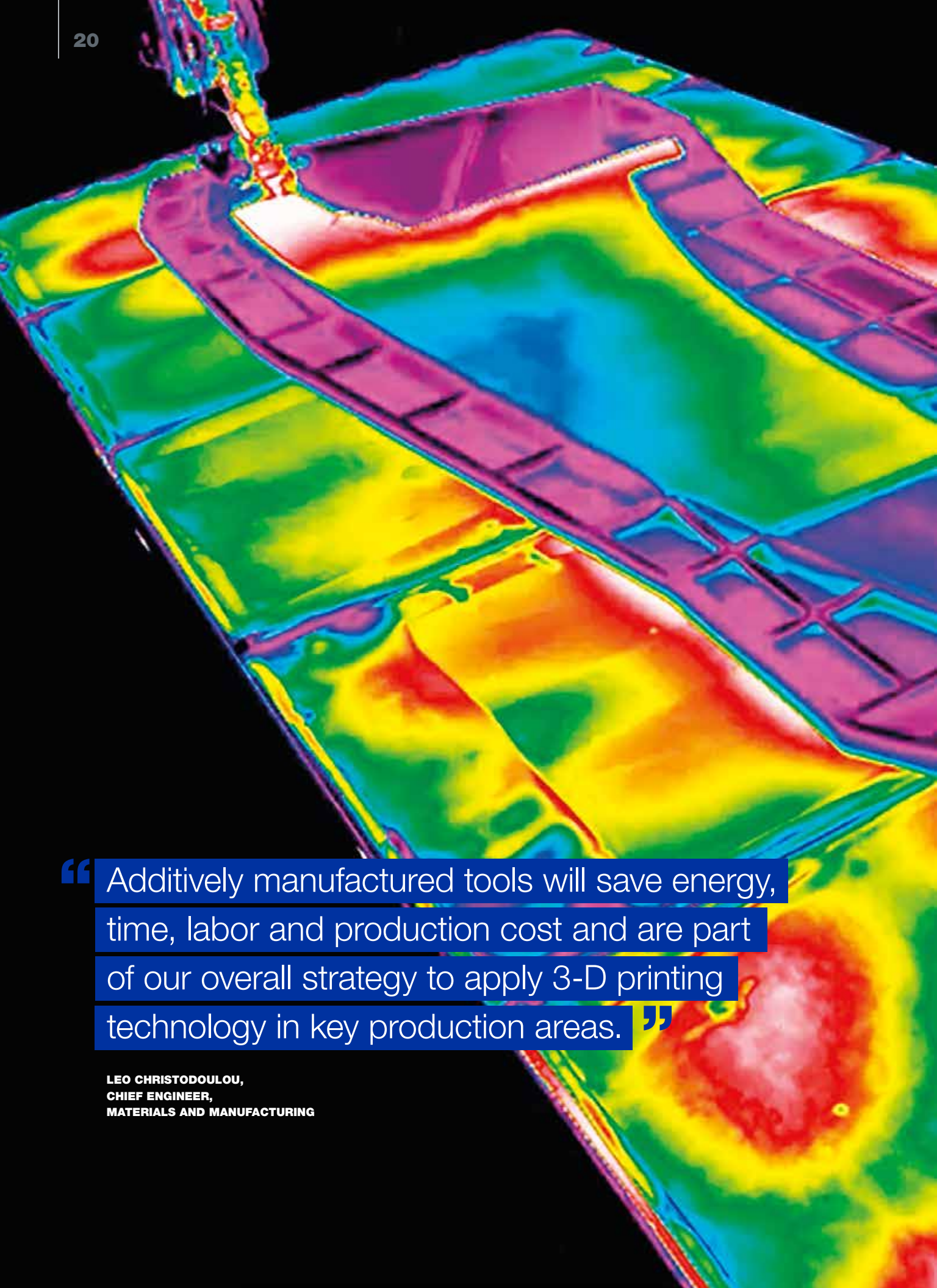

## What weighs around 1,650 pounds and is about as long as a large sport utility vehicle?

**It's the world's "largest solid 3-D printed item," just created by Boeing and one of its research partners, and certified by GUINNESS WORLD RECORDS.**

**BY MIKE MATLACK, COMPOSITE FABRICATION ENGINEER  
BOEING RESEARCH & TECHNOLOGY**

The item—which measures 17.5 feet long, 5.5 feet wide and 1.5 feet tall—is a wing trim and drill tool that Boeing will use to build its forthcoming 777X airplane. It represents our latest achievement in 3-D printing, also known as additive manufacturing.

To my own team and colleagues, the making of this tool exemplifies the tremendous efficiencies that 3-D printing will generate for this new airplane. But Boeing leaders also recognize that the creation of this item is just one example of what will be done with additive manufacturing in the near future.

"Additively manufactured tools will save energy, time, labor and production cost and are part of our overall strategy to apply 3-D printing technology in key production areas," explained Leo Christodoulou, Boeing's materials and manufacturing chief engineer, at the successful completion of the recent record-setting print.

Making the object through traditional manufacturing methods would have required about three months. Thanks to 3-D printing, we did it in only 30 hours.

Boeing has about 20 years of experience with this technology, having begun researching additive manufacturing in 1997. Today, there are about 50,000 3-D printed parts flying on Boeing commercial, space and military products. Recent advances in 3-D printing have allowed us and other designers and researchers to create parts of greater size and complexity.

BOEING PHOTO

Boeing plans to continue as the industrial leader of large scale AM tooling technology by developing new material systems and progressing into new tooling applications such as composite cure tooling. The team is also developing large-scale AM composite 350 F, 85 psi cure tooling technology, which has shown significant advancement and is predicted to be available for programs in 2017.

The wing trim tool, which will be used to secure the 777X composite wing skin for drilling and machining, was originally printed in May at the U.S. Department of Energy Oak Ridge National Laboratory (ORNL), one of Boeing's research partners. Since 2014, Boeing has worked with ORNL to develop a week-long training program for engineers focused on 3-D printing. So far, more than 100 Boeing engineers have completed the additive manufacturing training course at ORNL.

What's next for the world's "Largest solid 3-D printed item"? The tool will soon be used in production at Boeing's new St. Louis Composite Center of Excellence, where Boeing is designing and fabricating wing edge and empennage parts for the 777X. **IQ**

“Additively manufactured tools will save energy, time, labor and production cost and are part of our overall strategy to apply 3-D printing technology in key production areas.”

**LEO CHRISTODOULOU,  
CHIEF ENGINEER,  
MATERIALS AND MANUFACTURING**

Video of the tool being made can be found at [boeing.com/IQ](http://boeing.com/IQ).



**CHRISTI GAU PAGNANELLI**

director of systems engineering  
for Boeing Defense, Space & Security.  
Image captured from MIT course video.

**787 PRODUCTION LINE**

Every Boeing aircraft represents a complex system of systems, with multiple parts, disciplines and technical needs from concept to design, through build and into service. (Photo right)



BOEING PHOTO



# Live, learn and prosper

## Digital education partnership prepares the next generation of systems engineers

BY DARYL STEPHENSON

Call it a mindset more than a process. What's been referred to as a SPOC (small private online course) is really about innovation and advancing a systems way of thinking.

Together, Boeing, NASA and the Massachusetts Institute of Technology have forged a unique partnership to offer an online, four-course, architecture and systems engineering program that's primarily designed to boost the effectiveness of engineers and their careers. It's also expected to provide engineers with skills that are becoming increasingly valuable in the aerospace industry.

The MIT SPOC is the first implementation of a Space Act Agreement that Boeing and NASA signed in 2015. Through the agreement, Boeing and NASA are collaborating in secondary and post-secondary education to develop a skilled workforce to maintain the United States' technical leadership in the world.

The arrangement is attractive to Boeing because systems engineering is a key method that the company uses to develop products and work with suppliers and customers, said Christi Gau Pagnanelli, director of systems engineering for Boeing Defense, Space & Security.

"Model-based systems engineering is a relatively newer technique to systems engineering, and it's important that we get as many of our engineers as we can to adopt it because it's the way our future customers want to go,"

she said. "We hope (through the MIT program) to get a broader understanding of what model-based systems engineering is, and why we need it. In one way or another, all engineers do a little systems engineering, because we all work on complex systems. A broad-based awareness of systems engineering would be very beneficial to how we run our programs and develop our products."

In a promotional video for the MIT program, Gau Pagnanelli points out that as aerospace products become increasingly integrated and complex, the way engineers manage systems architecture is also becoming more complicated and critical than ever before. "Getting it right the first time is vital to keeping people safe, as well as moving forward to reach our goals," she said.

Students have the option to take the complete program of four courses to earn a professional certificate from MIT, or they may take classes individually.

The courses range from four to six weeks, contain about five modules each, and involve a time commitment of three to five hours a week. Students learn online, when and where they like, but must complete each module within the assigned time.

### The four courses in the certificate program are:

- Architecture of Complex Systems
- Models in Engineering
- Model-Based Systems Engineering: Documentation and Analysis
- Quantitative Methods in Systems Engineering

The first class began on Sept. 12, and the four-course program continues through March 12, 2017. The program is expected to be offered again in 2017.

Through online instruction, students have access to

## Boeing and NASA: Partners meeting a shared challenge

Boeing and NASA are co-signers of a Space Act Agreement in which they pool their resources to "motivate and educate the next generation of aerospace innovators to develop a workforce and provide the skills required to maintain America's technical leadership position in the world." The agreement, signed in 2015, involves collaboration in secondary and post-secondary education.

Two people instrumental in developing educational programs under the SAA are Charles Camarda, a NASA astronaut and senior advisor for engineering development at NASA Langley Research Center, and Michael Richey, a Boeing associate technical fellow.

Both have developed online, collaborative educational programs in which participants have worked on solving actual aerospace design problems, and they both believe that such an approach is the key to providing instruction that meets the needs of government and industry.

The Boeing-NASA agreement started with a recognition that they share a common problem.

"We looked at NASA's demographics and they're very similar to ours," Richey said. For example, there are a lot of knowledge, skills and competencies that are needed and there's a high cost of traditional education. "NASA's cycle of innovation and the skills they need are a little different than Boeing's, but the basics to the problem are the same. So the (agreement) is just a way to say, 'Hey, we're in this together, so why don't we partner?'"

He added that this partnership plays a critical role in workforce development, since feedback from industry and government experts can help provide competency-based guidelines for academic programs. This certificate represents the true partnership between Boeing, NASA, EdX and MIT, which has brought together subject matter experts in systems engineering, learning sciences, instructional designers, and data analytics specialists.

"The MIT courses represent our first output that we collaborate on together as part of this agreement," Camarda said. "It's very interesting. We have excellent faculty from MIT working with experts from NASA and Boeing to show students how they apply what they're learning. I think that's really the key to maintaining interest among students."



**GREG HYSLOP**

Boeing chief technology officer and senior vice president of Engineering, Test & Technology. Image captured from MIT course video.



top-notch research from MIT's faculty, combined with the expertise and hands-on knowledge of professionals from industry, and NASA. Using industry case studies and the latest in systems thinking from MIT, students gain foundational knowledge in complex systems, analysis of complex systems, and model management that will enable them to improve how they approach and solve complex technical challenges.

The program, titled Architecture and Systems Engineering: Models and Methods to Manage Complex Systems, represents "the largest investment by MIT in the online (educational) realm," said Bruce Cameron, MIT's faculty director of the MBSE certificate program.

MIT has been "experimenting" with online education for many years, and only recently has begun applying it in an actual, professional education setting, he said.

In 2012, MIT began a joint venture with Harvard University to create an online instructional platform called EdX, which is being used for this program.

MIT has been working with Boeing to develop the systems engineering program for the past year and a half. Though Boeing helped organize the content, several other companies have become involved to provide a diverse array of content, examples and case studies.

The overall purpose "is to grow systems engineering and modeling competencies of engineers," Cameron explained. "What frames this course is that we (meaning the technical community) build a lot of complex systems. For complex systems, no one really holds the whole system in his or her head. If you look at all that's involved in complex systems, we kind of get lucky when they work as well as they do. The key to getting the guesswork out of that is getting the architecture right. There's no guarantee, but you're much better off with a system that has a good architecture, because it's much more likely to meet the needs of its stakeholders."

The courses have a lot of discussion and interaction among students working in teams and with subject-matter experts and faculty, which is intentional, Cameron said. "We're looking to mix it up as students go through. We're pushing the idea of active learning."

"The value of this course is that it helps you be a more effective engineer today and tomorrow," Cameron added. "It's not about credit or promotion; it's about your effectiveness as an engineer." 

**Why systems engineering?**

What is systems engineering, and why is it so important to MIT, NASA, Boeing and other aerospace companies?

The International Council on Systems Engineering (INCOSE) defines it as "an interdisciplinary approach and means to enable the realization of successful systems. It focuses on defining customer needs and required functionality early in the development cycle, documenting requirements, then proceeding with design synthesis and system validation while considering the complete problem."

INCOSE goes on to say that systems engineering "integrates all the disciplines and specialty groups into a team effort forming a structured development process that proceeds from concept to production to operation. Systems engineering considers both the business and the technical needs of all customers with the goal of providing a quality product that meets the user needs."

INCOSE also describes a seven-step systems engineering process that involves stating the problem, investigating alternatives, modeling the system, integration, launching the system, and assessing performance.

Systems engineers, then, have to see the big picture—all aspects of it.

"Systems engineers have to be the advocates for the whole system," said Greg Hyslop, Boeing chief technology officer and senior vice president of Engineering, Test & Technology. "They really have to be the ones who understand where the margin is, understand the system performance, and then advocate for the entire system."

# Selections from the Boeing Technical Journal

## A peer-reviewed periodical for Boeing subject-matter experts.

Research coverage includes all manner of commercial and defense product development, and products and services spanning land and sea, to air and space, and cyberspace.

### Contributing Authors

#### LOW-COST VARIABLE-AUTONOMY GROUND VEHICLES



**Mahesh Chengalva** is a lead engineer in structural analysis at Boeing Commercial Airplanes with more than 20 years of experience, including time in the automotive industry.

#### CHECKLISTS TO ENHANCE SAFETY



**William Higgins** is a professional trainer and technical writer specializing in the development and implementation of critical checklists.



**Daniel Boorman** is a Boeing technical fellow, engineer and production test pilot specializing in electronic checklists and flight deck procedures.

#### INDUSTRIAL ATHLETE



**Sabyasachi Basu** is a Boeing associate technical fellow specializing in statistics and data analytics.

#### INDUSTRIAL ATHLETE



**Catherine Curley** is a program manager for the central Puget Sound injury prevention, rehabilitation and Well Being program.



**Laurence Wechsler** is Boeing's epidemiologist and conducts research relating to employee health and safety.



**Karen Rogers** leads the Industrial Athlete program in two Puget Sound locations.



**Deborah Smith** is a senior manager of global occupational health and was Chief Physician for the Boeing Everett site.



**Tina Hermans** leads the Industrial Athlete program in Everett.



**Corinne Towler** is the senior manager of Boeing's Industrial Athlete program.

# Low-Cost Variable-Autonomy Ground Vehicles

## Summary

BY MAHESH K. CHENGALVA

The year 2016 has been a particularly productive year for the commercial implementation of autonomous ground vehicle technology. Various automakers are racing to introduce autonomous transportation to the consumer market.

The U.S. National Highway Traffic Safety Administration released a long-awaited policy in September 2016 to lay a regulatory foundation for widespread use of autonomous vehicles on public roads. Together, both technological and regulatory needs must be solved for practical widespread use for autonomous ground vehicles.

While autonomous vehicle technology will eventually be safe and reliable, this is likely not the case in the near future. It remains to be seen how the rushed deployment of autonomous vehicles on public roads plays out, with all the risks associated with the technology.

However, within the constraints imposed by the state of the art, particularly in regards to reliability, there are military applications that

are feasible today. Unmanned Ground Vehicles (UGVs) have made considerable strides in the past decade since the three DARPA Grand Challenge competitions that were held in 2004, 2005 and 2007. The last of these was the DARPA Urban Challenge and specifically focused on the ability of autonomous ground vehicles to interact with other unmanned and manned vehicles.

While DARPA's primary objectives were achieved, some of the limitations of present-day technology were also highlighted. One of the more significant of these limitations is best illustrated by the autonomous vehicle from the Massachusetts Institute of Technology. The MIT team was one of the better performers in the contest, having successfully completed the designated course in the finals of the competition.

However, the power requirements of this vehicle's sensor and processing hardware was so extensive that it required an independent gasoline-powered generator strapped to the

roof for the needed electrical power. With the interior of the vehicle also entirely filled with relevant electronics, the payload capacity of this vehicle is considerably limited. Moreover, the expensive control hardware on board the vehicle far exceeds the cost of the vehicle itself. This limitation is not confined to the MIT vehicle; some of the teams participating in the Urban Challenge had spent in excess of \$10 million in developing their vehicles.

While this concept of "performance-at-any-price" may work in winning contests, the practical world demands much lower price points to enable adoption. One of the purposes of the DARPA Grand Challenge contests was to develop an autonomous supply vehicle for use in war zones. In this era of tight defense budgets, it would be difficult to market million-dollar autonomous vehicles as potential replacements to manned supply vehicles, even if all the capabilities are available.

The second major limitation highlighted at the DARPA Grand Challenges is in vehicle capability. It was seen repeatedly throughout the 2007 Urban Challenge that despite all the expensive hardware and elaborate software, vehicles were immobilized as a result of their inability to process a scenario that any human driver would have considered trivial. One such example was when a gate that was supposed to have been kept open unexpectedly

Despite the unique innovations, all vehicles were subjected to the same limitations—occasional inability to operate in seemingly trivial traffic situations.

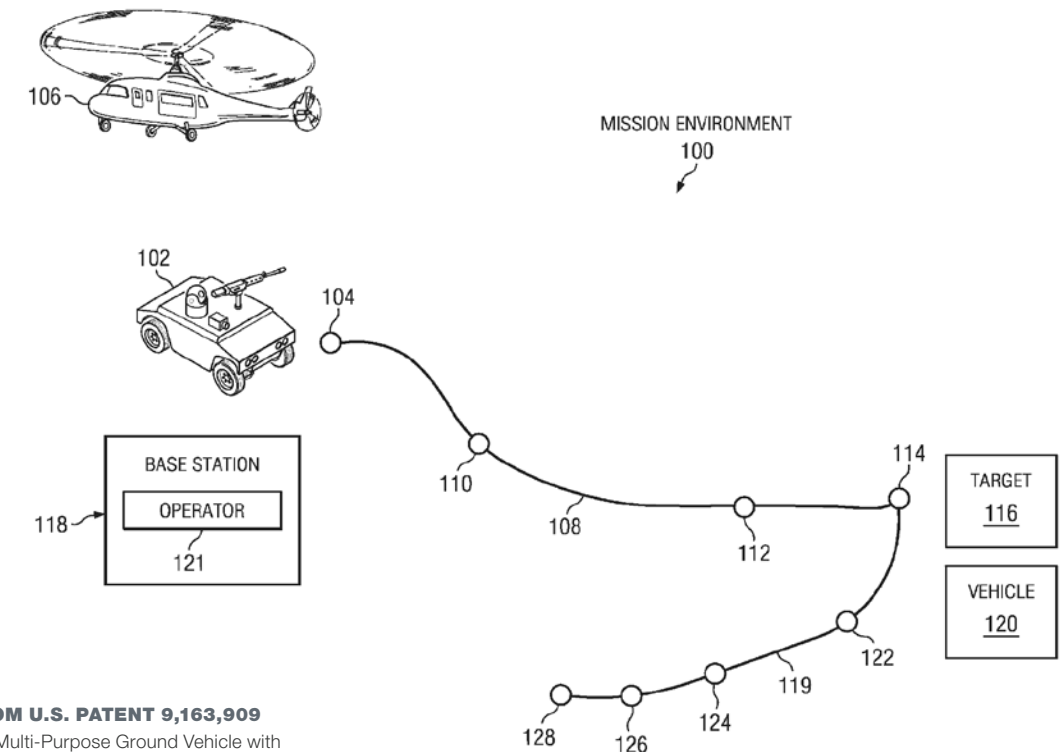

**FIG. 1 FROM U.S. PATENT 9,163,909**  
Unmanned Multi-Purpose Ground Vehicle with Different Levels of Control, granted Oct. 20, 2015.

closed, blocking a lane of the roadway. The MIT vehicle came to a complete stop when it encountered the gate blocking its lane, but would not change lanes and pass around the gate. It was only upon human intervention in the form of a crew that arrived at the scene and opened the gate that the MIT vehicle was able to continue on its mission.

While most of the participants at the DARPA Urban Challenge 2007 comprised vehicles with very expensive control hardware and software, there were some exceptions. Most notably, a team from Kokomo, Indiana, developed an autonomous vehicle for under \$20,000. The key enabler was a simplified vision and GPS sensor system that made use of commercially available off-the-shelf, lower-cost hardware.

Figure 2 is a photograph of the autonomous vehicle developed by this team (a semi-finalist), and as can be seen, many of the vision sensors were \$50 webcams intended for use with personal computers.

However, this system can, on some occasions, produce false positive results, i.e., the system detects an object that it classifies as an obstacle whereas in reality it is not of any concern. It should also be noted that the vision system, while providing a practical and effective input to the vehicle control system, is not designed to work in all lighting conditions. Performance can be degraded under very low or very bright ambient light. Under such conditions, the control system would have to shift to using alternate sensor input, such as GPS and short-range radar.

Despite the unique innovations, all vehicles were subjected to the same limitations—occasional inability to operate in seemingly trivial traffic situations.

It is not sufficient from the practical perspective that autonomous vehicles are able to handle 99 percent of the scenarios and fail whenever the remaining 1 percent is encountered. As seen in the 2007 DARPA Urban Challenge and cited earlier, million-

dollar autonomous vehicles were reduced to a state of immobility when encountering common traffic scenarios that would have been easily overcome by a human driver.

The most practical means of overcoming this is represented in a patent issued to Boeing in 2015. That is, couple autonomous ground vehicles with a remote human operator who is able to remotely intervene whenever the vehicle encounters a situation that it is not able to overcome.

For optimal performance, the level of involvement of the human operator is variable and entirely situation-dependent. Moreover, the transition of control between the autonomous vehicle control system and the human operator, and vice-versa, should ideally be seamless. This type of hybrid vehicle control utilizes the best of both realms and leads to a new class of vehicle—the Variable-Autonomy Ground Vehicle (VAGV).

While it may superficially appear that the VAGV concept is a step backwards





Combining low-cost with a variable level of autonomous control appears to be the most practical means of delivering reliable unmanned ground vehicles.

**FIGURE 2.**

A DARPA Urban Challenge vehicle, utilizing a low-cost vision system comprising mainly of personal computer webcams.

SOURCE: BOEING

in the development of autonomous vehicles, this concept is not entirely new, as can be seen from the Predator UAV control system. Although it has a limited level of autonomous operation, the remote human operator makes all the important decisions, particularly in regard to discharge of weapons. A similar control model is being extended here for autonomous ground vehicles, where remote operation through a high-bandwidth radio channel permits the human operator to manually take over control on a temporary basis until the obstacle or situation encountered is overcome.

The remote operator can be physically located at any convenient location which permits communication and control of the VAGV over a secure radio channel. This can be anywhere from the immediate proximity of the vehicle to the other side of the world, as is the case with the Predator UAV. Because the VAGV is able to maintain autonomous control most of the time, it is possible for one operator to handle multiple VAGVs in the field. The primary function of the operator is to intervene when requested by the VAGV navigation control system and to take manual control, if needed, of the VAGV's surveillance, fire control or other additional systems, when it is so equipped.

The main mode of communication from the VAGV to the operator is in the

form of a live video feed from various onboard cameras. These can also include infrared imaging cameras for night use.

While not essential for most missions, a Virtual-Reality helmet used by the remote operator, in which all the visual information streaming from the VAGV is appropriately projected inside the helmet, would provide a level of situational awareness that is second only to being present in the vehicle.

Using the combination of a proven low-cost approach, coupled with a variable level of autonomous control, appears to be the most practical means of delivering reliable unmanned ground vehicles capable of filling a variety of roles. Among the possible applications are autonomous supply vehicles in war zones, as casualty extraction

vehicles in certain circumstances, as ISR platforms with long range and endurance capability, as border patrol surveillance tools and even as assault vehicles capable of carrying a variety of armaments. Moreover, with the additional functionality of interoperability with other unmanned and manned air and ground systems, a significant enhancement in overall capability is achieved.

A rapid expansion into the adjacent area of unmanned/autonomous ground vehicles, particularly for the applications described here, is well within current technological reach and resources. 

To read and download the complete Boeing Technical Journal paper titled:

“Low-Cost Variable-Autonomy Ground Vehicles”

Please visit [boeing.com/IQ](http://boeing.com/IQ).

# Industrial Athlete

## Summary

BY SABYASACHI BASU | LAURENCE S. WECHSLER | DEBORAH R. SMITH | CORINNE D. TOWLER  
CATHERINE M. CURLEY | KAREN ROGERS | TINA L. HERMANS

Production and manufacturing operations at a large aircraft maker is a physically intense job. One might even call it a workout.

The Industrial Athlete program is an innovative, voluntary workplace program designed to improve the health and productivity of employees and address the need to keep employees strong and healthy.

In 2004 Boeing benchmarked program elements with another global, original equipment manufacturer. The outcomes were shared verbally with Boeing without documentation and were not substantiated by published studies in peer-reviewed literature. Thus, Boeing managers decided to capture elements of their own program for the purposes of analyzing outcomes. Data have been collected and analyzed since the inception of the program. Multiple analytic techniques have been used to assess the effectiveness of the program given the challenges of implementing and sustaining the program in a dynamic manufacturing environment.

The initial target of the Industrial Athlete program were Boeing Commercial Airplane employees and manufacturing organizations considered to be at “high-risk” of an occupational injury or illness; generally speaking, these were employees working in the factory who actually assemble the airplanes and major components. Traditionally,

these employees are the ones who had the highest injury rates and the most days away from work due to occupational injury.

Like professional athletes training for competition, the Industrial Athlete program takes aim at eliminating discomfort and pain that often results from performing a physically demanding job and improving physical resilience of the employees.

### The primary purposes of the Boeing Industrial Athlete program are:

1. Improve the overall physical resilience of Boeing employees to prevent the occurrence of occupational injuries and work-related time loss through a program called Job Conditioning;
2. Detect and treat early symptoms before they resulted in an injury through Symptom Intervention; and
3. Return injured employees to the workplace earlier than might otherwise be expected using traditional return-to-work methods by Work Hardening.

For the purposes of this paper, data from Work Hardening activity was not analyzed. Results from the Job Conditioning and Symptom Intervention programs, which might be considered preventative actions, are described.

### Job Conditioning

Certified athletic trainers and exercise physiologists analyze the physical demands of the employees' jobs and design group-style exercise programs to prevent injuries. The overall work demands of a crew and each individual in the crew are reviewed and then a customized conditioning program is created by the instructor. Program exercises focus on endurance, balance, flexibility and stability. Typically, each crew comes to the conditioning class as a group. Because the program is voluntary, employees can choose to end their participation at any time.

### Symptom Intervention

The Symptom Intervention program is designed to detect and treat the earliest symptoms of discomfort or pain before those symptoms progress to becoming an injury. The two components of Symptom Intervention are Deep Tissue Intervention and Athletic Training.

### Deep Tissue Intervention

Deep Tissue Intervention is a type of therapeutic massage that is performed by trained therapists who understand the work the employee performs on the factory floor. The massage is geared toward reducing discomfort in specific body areas, restoring musculoskeletal balance, and helping employees get

back to a more productive life. Each session is 20 minutes long and the employee comes to the Deep Tissue Intervention therapist in a factory location for the session.

**Athletic Training**

Athletic Training is meant to assess and resolve early symptoms and educate employees on self-care techniques to avoid future symptom progression or injury. Certified athletic trainers assess symptoms, apply first aid techniques such as ice, tape, and

manual therapy, and provide body mechanics training and postural education to relieve discomfort based on employee symptoms.

A total of 30,375 employees have gone through the Industrial Athlete program since 2005. Figure 1 shows the number of employees participating in each of the programs.

Almost 45 percent of the participants (13,733 out of 30,375) participated in more than one program element. This suggests that the employees

may feel the benefit after participating in one program element and then come back to participate in another, although we did not have specific data to verify this assumption. Among the 30,375 employees, 24,752 are current employees in Washington. The number of production and maintenance workers in Washingtonstate, our target group, is 30,988 out of which 17,447 or 56.3 percent, have participated in one or more of the Industrial Athlete programs.

**FIGURE 1.** Venn diagram of the number of employees in the different Industrial Athlete programs.

SOURCE: BOEING

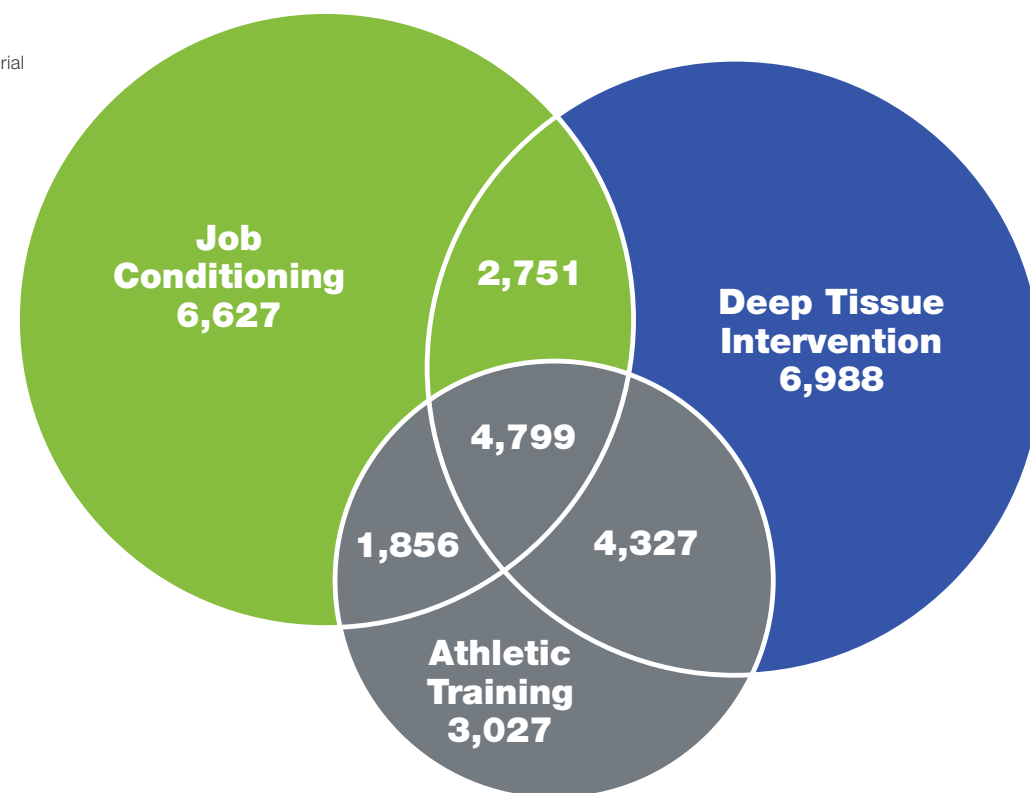

Like professional athletes training for competition, the Industrial Athlete program takes aim at eliminating discomfort and pain that often results from performing a physically demanding job and improving physical resilience of the employees.

The detailed analysis we present includes a pain and discomfort reduction due to participation in the Deep Tissue Intervention and Athletic Training programs, and survival models for the time to injury for different injury categories.

For each visit discomfort measurements were recorded—both before and after the Deep Tissue Intervention—in 97.6 percent of the visits, the employee reported a reduction in discomfort after therapy. In 2.4 percent of these visits, employees reported having the same level of discomfort, and 0.4 percent of the employees reported increase in discomfort.

Understanding that there is a human tendency to believe a benefit occurred if any intervention was performed, we assumed a discomfort level reduction of magnitude two or more points would reflect meaningful discomfort reduction. With this adjustment, 87.8 percent of the visits led to a reduction in discomfort. Therefore, it is believed that most of the visits to the Deep Tissue Intervention therapist are beneficial to the employee, even if the benefit is temporary.

Employees may choose to visit Athletic Trainers when they experience pain or discomfort while at work. During an Athletic Training engagement, the trainer evaluates and screens the employee's symptoms. Depending on the evaluation, the Athletic Trainer could refer the employee to a physician, refer to Deep Tissue Intervention, evaluate the workspace, or provide guidance to reduce aches and pain. As part of each session, the Athletic Trainer gives several recommendations to the employee to reduce discomfort. The top recommendations are stretching, icing the area of discomfort, body mechanics, posture education, taking micro breaks and strengthening of the affected area. They sometimes refer the employee for medical attention or to other company-provided programs.

Understanding that there is a human tendency to believe a benefit occurred if any intervention was performed, we assumed a discomfort level reduction of magnitude two or more points would reflect meaningful discomfort reduction.

Because discomfort or pain scale measurements are subjective, if we took a reduction in discomfort level of two or more to be substantial, 62.8 percent of the cases had a substantial reduction in the employee's discomfort level. In addition, it can also be anticipated that many of the Athletic Training cases with no follow-up visit was due to a reduction in discomfort after the Athletic Trainer visit.

In addition to the Symptom Intervention aspect of the program, all sites in the Puget Sound region of Washington state now use a standard Job Conditioning program comprising 60 minutes, 2 days a week for 7 weeks. Currently, the Boeing Industrial Athlete program is only in Washington state. But based on the effectiveness of the program, other Boeing sites in the

United States are investigating ways to start the program locally.

This voluntary program started at Boeing in late 2004 with the goal of reducing workplace injuries by improving physical resilience and eliminating the pain and discomfort that often results from performing a physically demanding job. By using sports medicine techniques, the program has been found to reduce discomfort after employee participation. Data also shows how athletic training participants show very small probability of injury of the same body part, even when looking at this probability after one year. 

To read and download the complete Boeing Technical Journal paper titled:

“Industrial Athlete: Implementation and Effectiveness of a Multifaceted Program for the Prevention of Occupational Injury”

Please visit [boeing.com/IQ](http://boeing.com/IQ).



# Checklists to Enhance Safety

## Summary

BY WILLIAM Y. HIGGINS | DANIEL J. BOORMAN

The concept of the checklist is so simple, and is used in so many ways today that talking of “critical” checklists does not leave much of an impression. Incorporating checklists in high-hazard environments has been one of the most influential innovations to enhance safety in recent times.

The defining moment leading to the innovation of using a formal checklist occurred in 1935.

The Army Air Corps was to award a contract for the next generation bomber, and three companies were bidding for the contract: The Douglas Aircraft Company with the Douglas DB-1, the Glenn L. Martin Company with the Martin 146, and Boeing with the Model 299. It was acknowledged that the Boeing four-engine plane with many new features was by far the better machine and the competition was purely academic. The Model 299 could fly farther, faster, and carry more payload than either of the other two entries.

However, during the demonstration trials the Boeing plane crashed and was destroyed, killing the two expert pilots and seriously injuring the engineers on board. This resulted in Boeing’s disqualification. Boeing’s internal investigation determined the pilots had made an error by not unlocking the wind gust-lock. The gust-lock, one of the new features

added, is engaged while on the ground to prevent elevator damage from high-wind situations, but must be released prior to take-off. When the Model 299 took off with the gust-lock engaged the elevators were inoperable.

When the competition demonstration flights had to be re-run because of a technicality, Boeing reentered the Model 299 with only one alteration: Boeing experts developed a series of normal checklists for the pilots to use to ensure that critical tasks were accomplished. As a result, Boeing won the competition and more than 12,000 of what became the B- 17 Flying Fortress aircraft were sold.

This paper examines the use of checklists in various high risk environments, and pre- and post-checklist implementation comparisons. We will also discuss human factors studies that form the foundation for the use of checklists, as well as draw parallels between what implementation teams in other fields have discovered when integrating checklists and the positive impact checklists can have on safety. The issues examined and conclusions documented can be used to support the development of critical checklists throughout any industrial application.

The following categories are indicative of the multiple uses of checklists:

- **Procedural checklists:** Excessively long, complex, or critical tasks performed only occasionally require “read-and-do” checklists (those checklists not done from memory, but the checklist is read and the various tasks performed sequentially) to ensure specific tasks in both normal and non-normal situations are accomplished.
- **Preparation checklists:** Multiple-step situations require checklists to ensure all of the variables are performed as desired; e.g. shopping lists, trip planning, group or individual communication sessions.
- **Problem-solving checklists:** Multiple-point, question type checklists used for troubleshooting complex procedures or tasks to pinpoint what went wrong, areas of difficulty, or solutions to barriers blocking forward movement.
- **Prevention checklists:** Critical checklists address errors, mistakes, mishaps in high-hazard work areas that can result in injury or death to users or neighbors, destruction of property, or impact to reputation or continued business success.

Each of these different uses has a particular purpose, and each has value and meaning as intended. While the use of checklists is present in almost every industry, extensive studies examining their effectiveness and the

science of how to develop effective checklists are almost non-existent except in the medical field, nuclear power, and the aviation industry. Our primary focus in this paper is to examine the effectiveness of prevention checklists in these industries, as well as in mining and rail transportation.

For example, in only the last two decades has the medical industry adopted a serious stance in preventing surgical errors by widespread adoption of using checklists.

In response to a shocking study published in 2000 that reported an estimated 44,000 Americans died each year as a result of preventable medical errors, a medical team at Johns Hopkins Hospital introduced several improvements, included and guided by a checklist termed the Comprehensive Unit Based Safety Program.

The program resulted in a reduction

of what is known as central-line associated bloodstream infection, a life-threatening condition, to nearly zero over four years. The Johns Hopkins results has led other medical institutions to implement similar patient safety programs. Additionally, in 2008, when the World Health organization deployed a Surgical Safety Checklist program, various healthcare systems, cultures and operating venues reported a 53 percent reduction in postoperative mortality and a 64 percent reduction in in morbidity.

The following implications, drawn from this analysis of processes undertaken to build a safety culture and in the use of checklists in numerous industries, provides insightful principles and practical strategies on how the development of critical checklists can have a positive impact on the development of a safety culture:

### 1. Understanding checklist use

- a. The use of checklists will not eliminate all accidents in the lab, test facility, production line or wherever they are implemented. Accidents will still happen even when users make decisions consistent with best practices because risk cannot be completely eliminated.
- b. Training classes and feedback can positively change personal behavior. Practical issues encountered during the implementation of checklists can be minimized by effective training.
- c. All employees must make decisions as to what steps, if any, they need to take based on a mental representation of the factors known or hypothesized in the ever-changing or semi-constant state of their equipment at any given point in time.
- d. “No repetition of incidents” must be a guiding principle, and if an incident

**Surgical Safety Checklist**

World Health Organization | Patient Safety

**Before induction of anaesthesia** (with at least nurse and anaesthetist)

- Has the patient confirmed his/her identity, site, procedure, and consent?  Yes
- Is the site marked?  Yes  Not applicable
- Is the anaesthesia machine and medication check complete?  Yes
- Is the pulse oximeter on the patient and functioning?  Yes
- Does the patient have a:
  - Known allergy?  No  Yes
  - Difficult airway or aspiration risk?  No  Yes, and equipment/assistance available
  - Risk of >500ml blood loss (7ml/kg in children)?  No  Yes, and two IV/central access and fluids planned

**Before skin incision** (with nurse, anaesthetist and surgeon)

- Confirm all team members have introduced themselves by name and role.
- Confirm the patient's name, procedure, and where the incision will be made.
- Has antibiotic prophylaxis been given within the last 60 minutes?  Yes  Not applicable
- Anticipated Critical Events
  - To Surgeon:
    - What are the critical or non-routine steps?
    - How long will the case take?
    - What is the anticipated blood loss?
  - To Anaesthetist:
    - Are there any patient-specific concerns?
  - To Nursing Team:
    - Has sterility (including indicator results) been confirmed?
    - Are there equipment issues or any concerns?
- Is essential imaging displayed?  Yes  Not applicable

**Before patient leaves operating room** (with nurse, anaesthetist and surgeon)

- Nurse Verbally Confirms:
  - The name of the procedure
  - Completion of instrument, sponge and needle counts
  - Specimen labelling (read specimen labels aloud, including patient name)
  - Whether there are any equipment problems to be addressed
- To Surgeon, Anaesthetist and Nurse:
  - What are the key concerns for recovery and management of this patient?

SOURCE: WORLD HEALTH ORGANIZATION

FIGURE 1.  
The WHO Surgical Safety Checklist.

## Determining the best way of proceeding in a complex operational setting is to acknowledge expertise and experience as an essential foundation to the use of checklists.

occurs it is necessary to learn from it to prevent the same incident from happening in the future.

- e. Internalization and generalization is central to the process of change. A change in communication can get people talking about safety differently than they communicated before an effective safety awareness program was implemented.
- f. Emphasis must be placed on the importance of checklist use with reminders of situations where deviations from checklists occur and how they can be misused.

### 2. Organizational changes that support checklist use

- a. It is crucial that performance evaluation and theoretical rhetoric proclaim the same message.
- b. Engaged senior leadership is essential to sustaining a culture of safety and the involvement of all levels of staff is critical to a successful safety and checklist initiative roll-out.
- c. Safety and checklists must be ingrained in organizational culture until everyone can say that checklists are just “a part of how we do business.”
- d. One key to organizational success in the use of checklists is to continue to search for errors, know their error rates, monitor them after implementing safety innovations, and give feedback to all staff so they know the science behind the checklists is valid. The use of

checklists is not the end-game; reduced error rates are.

- e. A key feature of a successful safety and checklist initiative is its rejection of a command-and-control regime where workers are simply told they are to use a checklist and expected to go and do it. Instead, they need to be encouraged to develop checklists that fit their own unique challenges and culture.
- f. To improve safety, it is critical that we shift from a perception where the prime cause of accidents is user errors to thinking of errors as the consequence of many factors that combine to create conditions for accidents, and how to reduce those conditions.
- g. A zero mindset to injuries, accidents, and occupational illnesses is necessary, and a belief that all injuries and occupational illnesses are preventable.
- h. Committed peer champions placed as “safety expert” in labs, test facilities, or manufacturing plants will stimulate discussions on safety.

### 3. Benefits of checklists

- a. Ensuring that all critical tasks are carried out.
- b. Encouraging a non-hierarchical team-based approach.
- c. Enhancing communication, catching near misses or potential complications early enough to correct them, and encouraging the use of technologies to manage anticipated and unanticipated complications.
- d. Workers will feel more empowered to control their own safety, more comfortable with their safety-related choices, and are more likely to confront anyone asking them to perform an unsafe procedure when a safer one is available.

Checklists are a good way of making certain that tasks get done, but determining the best way of proceeding in a complex operational setting is to acknowledge expertise and experience as an essential foundation to the use of checklists.

Pre-planned procedures and checklists cannot replace the necessity of users bringing to bear diagnostic and response strategies in real-time based on their experience, collaboration and attentiveness when the confluence of influencing factors on any given piece of equipment, test or facility requires it. 

To read and download the complete Boeing Technical Journal paper titled:

“An Analysis of the Effectiveness of Checklists when Combined with Other Processes, Methods and Tools to Reduce Risk in High Hazard Activities”

Please visit [boeing.com/IQ](http://boeing.com/IQ).

# A unique research environment in Brazil

## Geographic advantages open opportunities for discovery

BY GLAUCIA BALVEDI, ADVANCED TECHNOLOGIST | JOSÉ ALEXANDRE FREGNANI, ADVANCED TECHNOLOGIST  
BOEING RESEARCH & TECHNOLOGY-BRAZIL

Since the opening of its research center in São José dos Campos, Brazil, Boeing Research & Technology-Brazil quickly became a locus to lead innovative research.

The center is an integral component of Boeing’s global innovation network, driving world-class research collaborations with the universities of Sao Paulo, Brasilia, Minas Gerais and Unicamp, organizations such as the National Institute for Space Research, and with industry partner Embraer. Leveraging the opportunities provided by key United States-Brazil bilateral trade agreements, the Boeing research center’s globally competitive local talent pool focuses on key R&D areas of flight sciences, airspace operation efficiencies, metals and biofuels.

Two projects led by and conducted at Boeing’s research center are representative of the unique research and technology development opportunities in Brazil:

### Ionosphere Studies and GPS Augmentation Systems

This work comprises the study of interactions of the ionosphere with satellite-based aeronautical navigation systems. The ionosphere is a layer of the atmosphere from 50 km to about 1000 km above the Earth’s surface that contains high density electronic plasma due to solar radiation. Brazil is located under the geomagnetic

equator (a low latitude region where the plasma is often least dense), which means that it is subject to radiation-induced ionospheric disturbances and anomalies more frequently. One consequence, is the occurrence of disruptions to Global Positioning System (GPS) signals.

These anomalies prevent satellite-based aeronautical navigation systems, such as Ground Based Augmentation Systems (GBAS), from being fully operational in Brazil and the South Atlantic regions. GBAS is a differential augmentation system designed to correct pseudo range errors on GPS signals in a vicinity of airports, enabling the execution of precision approach procedures based on the Performance Based Navigation (PBN) concept. It meets the stringent operational needs of aviation, is more economical than conventional ILS (Instrument Landing System), and has low installation, maintenance and lifecycle costs.

GBAS has tangible benefits for airlines and other aircraft operators, such as airport capacity gain of 9-12 departures per hour, reduced communications, improved PBN operations, fuel savings and automation of routine ATC functions. Enabling GBAS operations in Brazil would lead to better use of an airplane’s capacity. Boeing has around 15 percent of its GBAS-equipped customers in low latitude areas, indicating unused technological capabilities by airlines, aeronautical services providers and airports.

Boeing concluded an extensive preliminary research on the ionosphere phenomena. The center acquired scintillation monitors (GPS receivers with special features) to collect ionospheric data in order to develop the calibration of statistical correction models. The monitors will be integrated in the Brazilian GPS network to obtain consistent data to enable the development of a Brazilian Ionosphere Disturbance Threat Model,

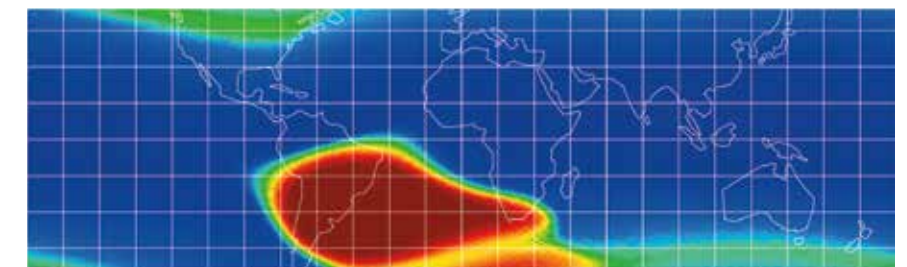

### SOUTH ATLANTIC ANOMALY

Ionospheric disturbances in the South Atlantic present a research opportunity for Boeing.

SOURCE: NASA



which will be implemented in the GBAS stations in the future. It is also envisioned flight tests to validate the model and certification process.

#### Aeroacoustics

Efforts towards aircraft noise reduction are of paramount importance since noise regulations have become increasingly stringent in order to limit noise levels generated by aircraft. In recent decades, significant jet noise reduction has been achieved due to efforts on the design of more efficient and quieter turbofan engines.

Since then, airframe noise associated with the unsteady turbulent flow around the aircraft has become a significant source of noise. Therefore, improving prediction techniques for airframe noise generation and propagation is a key topic in aeroacoustics research. Reduction of airframe noise is a complex task since its generation may be intrinsically related to the aircraft aerodynamic and structural performances. For example, landing gears, engines and slats noise may become leading source of airframe noise on next generation of transport aircraft designers are receptive to ideas to minimize noise.

Understanding the sources of noise can be derived from wind tunnel testing and flight testing but this is expensive computational approaches may offer a more economical approach to evaluate designs.

Currently Boeing conducts, with leading-edge academic partners in Brazil, research on faster CFD modeling techniques and cost effective wind tunnel testing related to selected nose landing gear configurations. Next year the activities will be expanded to more complex aircraft geometries envisioning future product developments. **IQ**

## Global Scale

No matter where they are, Boeing and its partners are at work to accelerate growth, productivity, research and innovation. Here is a snapshot of a few of the technical projects in work with dozens of joint research centers and consortia worldwide.

#### Boeing updates French air warning and control system

Boeing recently completed upgrades on the Airborne Warning and Control System (AWACS) for the French Air Force. The technology refresh features new user interface, enhanced "friend or foe" identification, streamlined data presentation and computing power that improves battle management capabilities. The system simplifies user access, saves operators' time, and is already in use.

#### Collaborative research in Queensland

Boeing Research & Technology–Australia has announced a research collaboration with the University of Queensland. The BR&T Brisbane office, laboratories and approximately 30 staff will relocate to UQ's St. Lucia campus, enabling a deeper collaboration with students and researchers on topics including bioterrorism countermeasures, autonomous systems, unmanned aircraft and environmental monitoring technologies. Boeing has been working with UQ since 2003, providing investments to support a variety of research projects such as sustainable fuel at UQ's Australian Institute of Bioengineering and Nanotechnology.

#### Data analytics solutions focus of Vancouver Lab

How can massive amounts of data be used to improve business? At Boeing's new open-concept laboratory in Vancouver, British Columbia, multi-disciplined teams with skills in UI/UX design, data science, consulting and Agile software-development are leveraging skills and software to help solve the problem. The team is developing data analytics-driven solutions that help Boeing's global customer base increase efficiencies and drive costs out of their businesses. The labs are designed to maximize creativity and collaboration in order to rapidly conceive, build and scale solutions. They also network with other data analytics driven parts of Boeing and its family of companies.

# Patent Spotlight

Check out a few of Boeing's latest ideas and technical breakthroughs recently acknowledged by the U.S. Patent and Trademark Office.

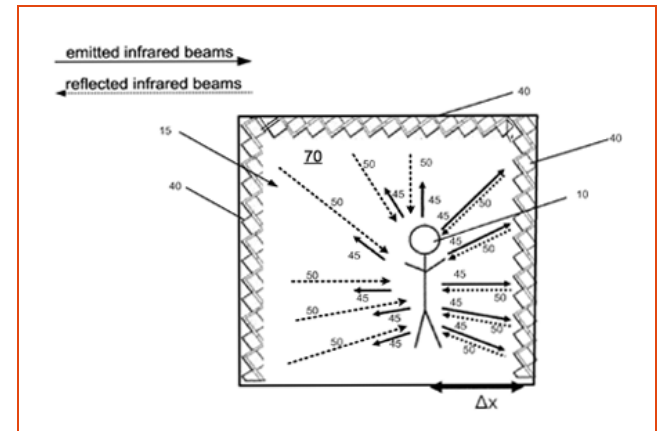

#### Retroreflective heater

U.S. PATENT: 9,423,538

INVENTORS: BRIAN J. TILLOTSON, ZACH J. HARRIS

A problem that has plagued us since time began: how to keep warm things warm and cold things cold.

People and objects gain or lose heat four ways: conduction, convection, evaporation and radiation. Approaches to maintain temperature stability often address one or more of these. But active heating or cooling systems are not practical in many instances. And there are instances where wrapping a person or object with insulation is impractical.

Adding to the multitude of inventions for maintaining temperature comes this Boeing patent using retroreflectivity. The invention comprises a covering or material having a plurality of retroreflective elements configured to reflect electromagnetic energy primarily at thermal infrared wavelengths back toward the target. Half the heat a person loses in cold environments may be infrared radiation. Through the retroreflective design, for example, heat that a person naturally emits could return directly to the person instead of scattering away.

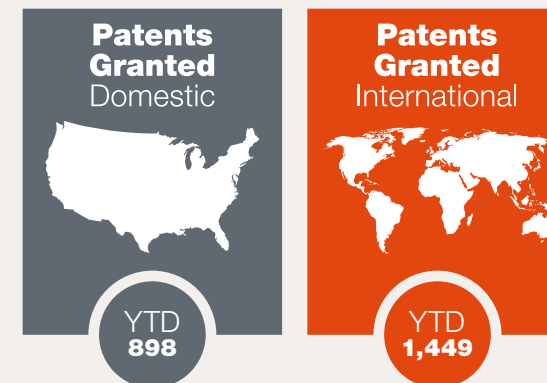

#### 2016 Boeing patents

Most of Boeing's intellectual property is in the form of trade secrets. Yet, with a healthy patent portfolio in the United States and internationally, Boeing is a recognized aerospace leader, and has been acknowledged for the last five years as one of the Top 100 Global Innovators by Thomson-Reuters, a worldwide information and media company.

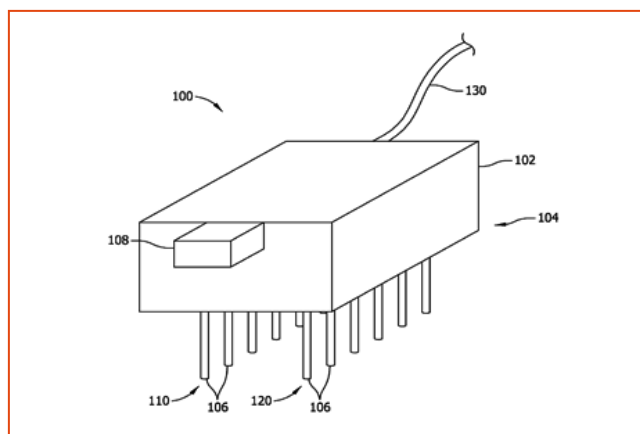

### Filtration system and methods for filtering particles of a predetermined substance

**U.S. PATENT: 9,352,256**  
**INVENTOR: DONALD F. WILKINS**

Recent advances in micro- and nano-sized electro-mechanical systems enable robots to be fabricated in increasingly smaller sizes. At least some known miniature robots may be small enough to operate in environments that are inaccessible or dangerous to humans, such as tight passages or in situations where the use of heavy equipment would be undesirable or impossible.

Two patents granted to Boeing recently involve technology using robotic micropillars in an innovative way. One invention is for the robot itself, a machine that propels itself using tiny pillars, or legs. A second invention uses those micropillars to create a more effective filtration system.

Common filtration systems use a medium to separate particles from a larger flow based on the particles' size. But these filtration systems can be both cumbersome (filters need to be changed or cleared of trapped particles) and ineffective (particles that are the same size or smaller can't be separated from each other). This new filtration system takes an array of micropillars and configures the array to either repel or attract particles of a predetermined substance. This allows particles of different substances, but of substantially similar size, to be separated. Micropillars can be additionally beneficial because they can be produced in the micrometer and sub-micrometer ranges.

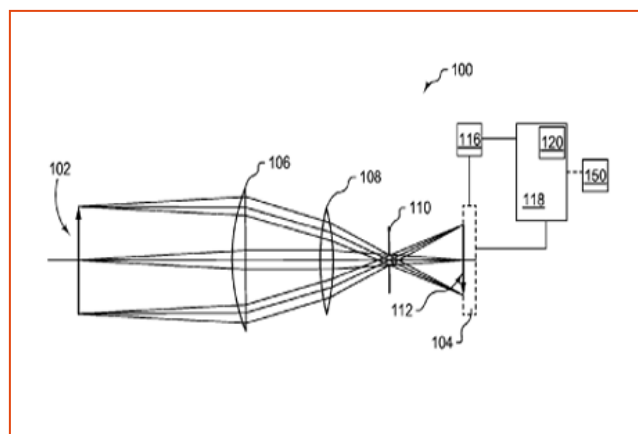

### Move based and sonic based super resolution

**U.S. PATENT: 9,430,814**  
**INVENTOR: KEITH D. HUMFELD**

Technology to enhance resolution in camera systems has been integrated in a variety of forms via computer software or physical optics. However, resolution enhancement technology may be limited in digital camera systems because standard charge coupled device (CCD) camera data is sorely limited by a size and count of individual pixels. Computer processing techniques, called Super Resolution processing, combine numerous images into a single higher-resolution image. However images can only be combined if certain criteria are met.

This patent recently granted to Boeing describes move-based and sonic-based camera modes that enable the camera to produce numerous images that are appropriate for super-resolution processing—a technique that may be easily implemented without significant expense. The move mode or sonic mode may be turned on and off depending on whether Super Resolution images are desired.

These systems and techniques may be used for satellites, unmanned aerial vehicles, and other surveillance platforms used for the purpose of intelligence, surveillance and reconnaissance, and for other everyday civilian environments.

## From the Innovation Video Playlist



# Air refueling in 3D

In current U.S. Air Force tankers, air refueling operators lie on their bellies in the tail of the aircraft and visually direct—or “fly”—the boom to the receiving aircraft. There's only a single light on the tip of the boom to see at night.

In the new Boeing-built KC-46A Pegasus tanker, the boom operator sits comfortably at an Air Refueling Operator Station console, behind the flight crew, and uses super high-definition 3D cameras and displays to help guide fueling boom link-ups. That makes it safer and easier to do, especially at night or in limited visibility.

View this video and other Boeing Short Films on [boeing.com/innovation](http://boeing.com/innovation).



Lag

Purs

Lead

# BREAKING THE NORM

Boeing T-X is a better trainer from the ground up, a clean-sheet design created with industry-leading investment, built to train pilots for the way they fly and fight in modern combat. With state-of-the-art manufacturing and unprecedented efficiencies, it's a complete advanced pilot training system designed to break the cost curve and the norm.



 **BOEING**

**T-X**

[BOEING.COM/T-X](http://BOEING.COM/T-X)