

# Innovation Quarterly

2019 Q3  
Volume 3, Issue 12

## **By the Code**

Taking a pledge of  
technical excellence

## **Intercepted**

A security success

## **Sustaining Growth**

The adoption of biofuels  
to power the fleet

A publication of The Boeing Company



## PUBLISHER

Greg Hyslop  
Boeing Chief Technology Officer

## ASSOCIATE PUBLISHER

Peter Hoffman  
VP Intellectual Property Management

## EXECUTIVE ADVISORY BOARD

Heidi Capozzi, Todd Citron, Ted Colbert,  
Lynne Hopper, Naveed Hussain, Gary Wicks

## EDITOR

Candace Barron

## DEPUTY EDITOR

Junu Kim

## CONTRIBUTING EDITORS

Will Wilson, Carrie Arnold,  
Brett Jensen, Sydney Palese

## GRAPHICS AND DESIGN EDITOR

William Crane

## DESIGN TEAM

Kim Proescholdt, Clayton Chu,  
Teresa Stanker, Bruce Becker

## DIGITAL TEAM

Conan Kisor, David Parke

## PATENT SPOTLIGHT

Melanie Morrill

## BOEING TECHNICAL JOURNAL

Ken Hardman, John Adrian, Gary Ray

## TECHNOLOGY INTELLIGENCE AND TRENDS

Marna Kagele, Will Wilson

## LEGAL ADVISER

Tom Donahue

## COMMENTS

Comments and letters are welcome and  
may be published in subsequent editions.  
To submit a letter to the editor, email  
candace.k.barron@boeing.com.

## WEBSITE

boeing.com/IQ

## ON THE COVER

Rogie Rodriguez-Quinones is a  
metallurgist and materials engineer  
working in Huntsville, Alabama.

PHOTOGRAPHY BY J.P. BOND

## Featured

### 16 | Successful salvo for security

Vitaly important to the defense of the United States homeland, the U.S. Missile Defense Agency in March successfully took down an intercontinental ballistic missile target with a ground-based interceptor designed and built by Boeing.

### 18 | A code that you can live by

They might seem like old-fashioned values, but duty, dedication and respect are timeless principles by which all Boeing engineers live. As an obligation to customers, to the world, and to one another, seven Boeing innovators sat down to talk to us about what it means to follow the Boeing Engineering Code.

### 32 | Making the grade in biofuels

In a little more than a decade, Boeing has taken the idea of sustainable aviation fuels from strategy and development to testing, to today when all airplane customers taking delivery of a new Boeing aircraft in Washington state will have the option of using biofuel on their journey.

## Technical Papers

### 26 | Checklists to Enhance Safety

Boeing pilots and other aviators have used checklists for more than 75 years. Surgeons, astronauts and other professionals have adopted checklists for routine situations. Incorporating checklists in high-hazard environments has been one of the most influential innovations to enhance safety. Using critical checklists, a specific application of checklists defined in this paper, could provide a safety interface between high-hazard processes and potentially devastating results. This paper examines the use of checklists in various high-risk environments, and pre- and post-checklist implementation comparisons.

### 29 | Determination of Thermoplastic Composite Crystallization Process Limits for Dynamic and Isothermal Cooling Processes

This paper interrogates the relationship between composite laminate consolidation (or thermal forming) cooling process parameters and crystallization kinetics of thermoplastic polymer composite matrix materials. Previously, a trial and error methodology has been used to determine the consolidation parameters for the multiple consolidation methods, where each method requires a unique set of parameters. It is proposed that the application of the Avrami Model for crystallization kinetics of semi-crystalline polymers can be applied to determine cooling-based process parameters for thermoplastic composite laminate consolidation and thermal forming.



# Committed to engineering excellence

Boeing is a company of innovators. For more than 100 years, we've embraced big goals and tough challenges to change the future of aerospace. That same drive to define what comes next continues today in our people, who are committed to technical excellence.

You can see it in the innovation and development underway across the company, more now than at any time in our history. While these advancements require us to think and act differently, our commitment to rock-solid engineering will never change.

I've experienced this firsthand. As the lead engineer on a project earlier in my career, I watched my pilot friend climb into the cockpit of a prototype aircraft and fly it for the first time. He landed safely, and I exhaled with admiration and relief. Knowing someone's life depends on your work is an unforgettable feeling, and it's one shared among all of us at Boeing.

When an accident occurs, we feel it deeply across our company and it intensifies our dedication to designing, building and supporting the safest products in the industry. This is true with the recent Lion Air Flight 610 and Ethiopian Airlines Flight 302 tragedies, which continue to weigh heavily on us.

We have no competing priorities when it comes to our values, including safety, quality and integrity. Together as a One Boeing team, we'll create a stronger company and industry for generations to come—always with a focus on technical excellence.

In this issue you'll read about what excellence means to our technical talent and how it translates to the advancements we're making from seabed to space. With an unwavering commitment to quality engineering and our values, we'll continue to prove the future is built here. 

**DENNIS MUILENBURG**

Chairman, President and Chief Executive Officer,  
The Boeing Company

**Recognizing Advanced Developments and Research**

# Technology RADAR

People working in Boeing's Technology Intelligence and Trends community of practice are human sensors in the world of science and technology. We make it our business to watch for innovations in practice, new business models and new ways of thinking. Here's a peek at a few signals on the screen.

**How to measure innovation**

Companies routinely say innovation activities are a high priority, but they struggle to understand how they are performing and which actions help them innovate most effectively.

Of-suggested metrics of innovation range broadly and include the amount of money spent on research and development, patent output, new products or services launched, and sales as a return on investment. Any of these measures taken in isolation is insufficient and can even be misleading or drive undesirable behavior.

The definition of innovation remains unclear for many. For example, technical replications and process improvements are sometimes overlooked in the innovation metrics conversation.

This is a challenging problem with no clear answer that works for every company. Effective solutions will need to take a more holistic approach, including elements like innovation resources available to employees, engagement and resulting improvement projects. **IQ**

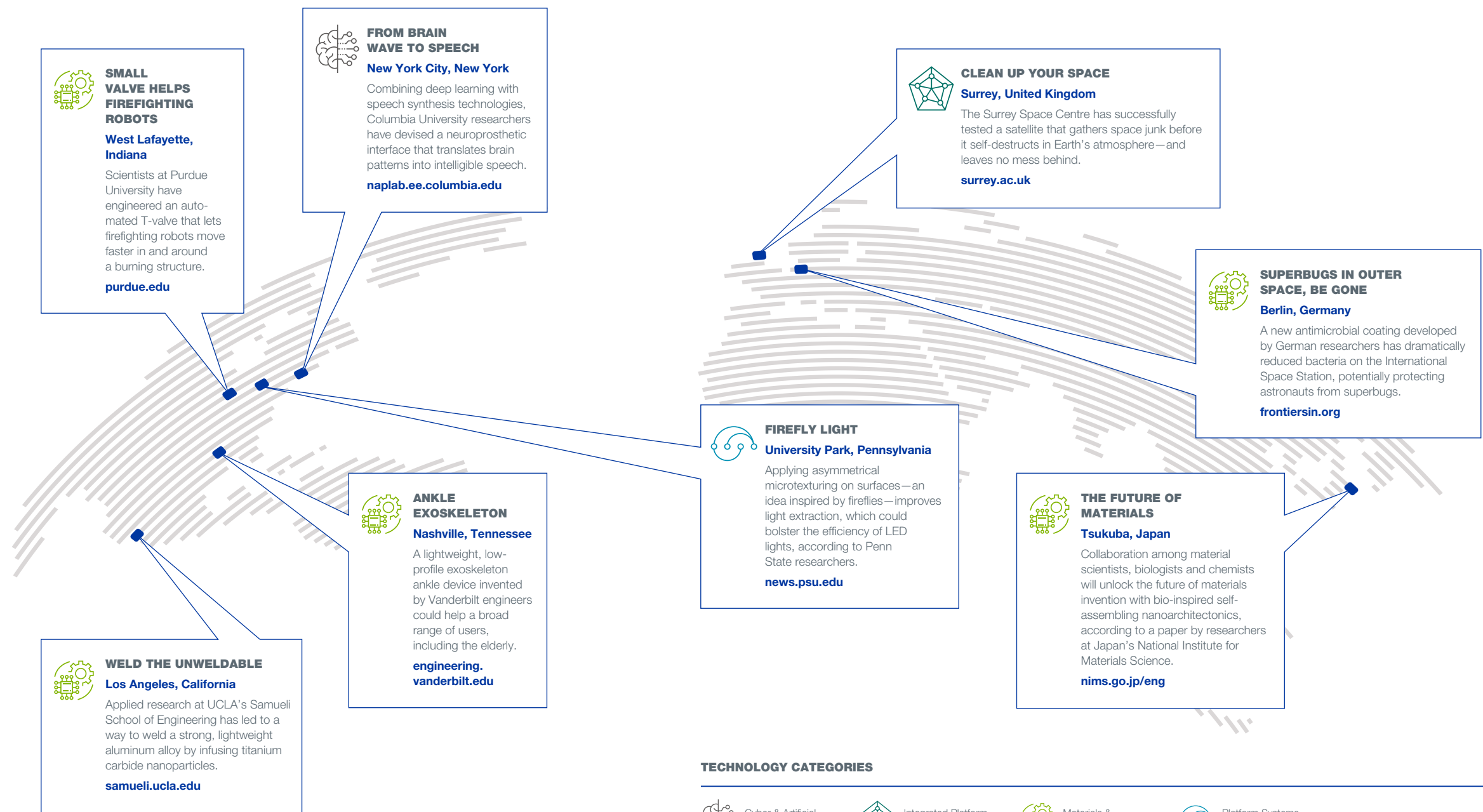

**TECHNOLOGY CATEGORIES**

-  Cyber & Artificial Intelligence
-  Integrated Platform Performance
-  Materials & Manufacturing
-  Platform Systems & Subsystems

# A word about the **Boeing** 737 MAX

BY BOEING TECHNICAL AND STAFF WRITERS

**The Boeing 737 made its first flight on April 9, 1967,** and was delivered to its first airline customers in December of that year. It has been continuously manufactured since, and the 737 family has continued to incorporate lessons and advances with each new model. Working with airlines and regulators, Boeing has developed and implemented thousands of safety and efficiency improvements within the 737 family. As a result, its safety record has improved with each generation of models.

PHOTO: BOEING



In multiple sessions, Boeing, the airlines and local regulators worked to identify desired improvements to the 737 family.

### 737 MAX Design Development

The 737 MAX is Boeing's newest model of single-aisle airplanes. The family includes the 737 MAX 7, 737 MAX 8 and 737 MAX 9. The program has also launched the 737 MAX 8-200, a new variant based on the 737 MAX 8, and the MAX 10.

The 737 MAX was designed and delivered on a disciplined six-year schedule. By way of comparison, Boeing took five years to design and deliver the all-new 777 in the early 1990s.

To develop the 737 MAX, Boeing brought together the 737 airline working groups, comprising pilots, engineering, maintenance and operations leaders from major airlines around the world. In multiple sessions, Boeing, the airlines and local regulators worked to identify desired improvements to the 737 family.

The 737 MAX's more efficient structural design, lower engine thrust and less required maintenance are designed to give customers substantial cost savings. The 737 MAX incorporates the latest quiet engine technology to reduce the operational noise footprint, and emissions will be nearly 50 percent below the International Civil Aviation Organization's (ICAO) Committee on Aviation Environmental Protection (CAEP)/6 limits for nitrogen oxides.

The 737 MAX family includes design updates, such as the Boeing Advanced Technology winglet, that reduce fuel use and CO2 emissions by at least 14 percent compared to Next-Generation 737s. Other design changes are LED landing, taxi and runway lights and a redesigned electronics bay.



PHOTO: BOEING

The 737 MAX improved on Next-Generation 737 range with the capability to fly more than 3,500 nautical miles (6,510 km), an increase of 340-570 nmi (629-1,055 km). The 737 MAX also incorporates quiet engine technology to reduce the operational noise footprint of the airplane by up to 40 percent.

Based on experience from the 787 and previous programs, the MAX primary flight displays include the enhanced sky-ground horizon line, providing the flight crew with additional situational awareness.

The 737 MAX displays are the latest in this evolution.



PHOTO: BOEING

### ADVANCED FLIGHT DECK

Boeing designed four, larger flat-panel displays into the 737 MAX using innovation introduced with the 787 Dreamliner airplane, which gives pilots more space and clarity in the flight deck.

### 737 MAX Flight Deck Displays

All primary flight information required to safely and efficiently operate the 737 MAX is included on the baseline primary flight display. This is true of all Boeing aircraft.

Crew procedures and training for safe and efficient operation of the airplane are focused around airplane roll and pitch attitude, altitude, heading and vertical speed—all of which are integrated on the primary flight display. All 737 MAX airplanes display this data in a way that is consistent with pilot training and the fundamental instrument scan pattern that pilots are trained to use.

The angle of attack (AOA) indicator provides supplementary information to the flight crew. The AOA disagree alert provides additional context for understanding the possible cause of air speed and altitude differences between the pilot's and first officer's displays. Information for these features is provided by the AOA sensors.

There are no pilot actions or procedures during flight that require knowledge of angle of attack.

Some operators have their own tailored training requirements and have requested that AOA information be included on the primary flight display. Boeing has offered the optional capability to provide that information. However, not all customers wish to include this feature on their primary flight display, so it is offered as a customer-selected option.

### Maneuvering Characteristics Augmentation System Overview

The MCAS (Maneuvering Characteristics Augmentation System) flight control law was designed and certified for the 737 MAX to enhance the pitch stability of the airplane—so that it feels and flies like other 737s.

MCAS is designed to activate in manual flight, with the airplane's flaps up, at an elevated angle of attack.

Boeing has developed an MCAS software update to provide additional layers of protection if the AOA sensors provide erroneous data. The software was put through hundreds of hours of analysis, laboratory testing, verification in a simulator, and two test flights, including an in-flight certification test with Federal Aviation Administration (FAA) representatives on board as observers.

### The additional layers of protection include:

- Flight control system will now compare inputs from both AOA sensors. If the sensors disagree by 5.5 degrees or more with the flaps retracted, MCAS will not activate. An indicator on the flight deck display will alert the pilots.
- If MCAS is activated in non-normal conditions, it will only provide one input for each elevated AOA event. There are no known or envisioned failure conditions where MCAS will provide multiple inputs.
- MCAS can never command more stabilizer input than can be counteracted by the flight crew pulling back on the column. The pilots will continue to always have the ability to override MCAS and manually control the airplane.

Boeing has created updated computer-based training to accompany the software update.



## Key Definitions

### Maneuvering Characteristics Augmentation System (MCAS)

Flight control law implemented on the 737 MAX to improve aircraft handling characteristics and decrease pitch-up tendency at elevated angles of attack.

### Angle of Attack (AOA)

The difference between the pitch angle (nose direction) of the airplane and the angle of the oncoming wind.

### Angle of Attack Sensor / Vane

Hardware on the outside of the airline that measures and provides angle of attack information to onboard computers; also referred to as an AOA vane.

### Angle of Attack Disagree Alert

A software-based information feature that alerts flight crews when data from left and right angle of attack sensors disagree. This can provide pilots insight into air data disagreements and prompts a maintenance logbook entry.

### Angle of Attack Indicator

A software-based information feature that provides angle of attack data to the flight crew through the primary flight displays. It is an option that can be selected by customers.

### Control Law

A set of software that performs flight control function or task.

### Flight Crew Operations Manual Bulletin

Supplementary operations information.

### Flight Operations Technical Bulletin

Supplementary technical information.

### Speed Trim System

A system that uses multiple components to provide additional speed or pitch stability when needed.

These updates reduce the crew's workload in non-normal flight situations and prevent erroneous data from causing MCAS activation.

## Training

To earn a Boeing 737 type rating, pilots must complete 21 or more days of instructor-led academics and simulator training. Differences training between the NG and MAX include computer-based training and manual review.

Boeing has created updated computer-based training to accompany the software update. Once approved, it will be accessible to all 737 MAX pilots. This course is designed to provide 737 type-rated pilots with an enhanced understanding of the 737 MAX Speed Trim System, including the MCAS function, associated existing crew procedures and related software changes.

### Pilots will also be required to review:

- Flight Crew Operations Manual Bulletin
- Updated Speed Trim Fail Non-Normal Checklist
- Revised Quick Reference Handbook. 



PHOTO: BOEING



**BETH PASZTOR**  
PRODUCT SAFETY  
ENGINEERING

# Boeing and the aviation industry

## A culture of safety

As air travel has grown over the decades, commercial flight has developed into the safest form of transportation according to the statistics. In 2018, the accident rate was one major jet accident for every 5.4 million flights. That's because of the commitment from everyone in the industry to learn from all forms of data, including accidents and incidents.

When there have been aviation accidents or incidents, such as those involving the 737 MAX, it affects us all very deeply. In our grief, the industry rallies together to make meaningful improvements, making air travel even safer. It's how we ensure that we never forget those lost and the important lessons learned through investigations.

The Commercial Aviation Safety Team (CAST) comprises hundreds of representatives from airlines, labor, government and manufacturers, including Boeing. Established in 1997, CAST had immediate impact, reducing the fatal accident rate in the United States by 83 percent in the 10-year period from 1998 to 2008.

CAST efforts helped facilitate improvements like terrain avoidance systems. Before the development of these "look ahead" warning systems, controlled-flight-into-terrain (CFIT) accidents had been a leading cause of airplane accidents involving loss of life. Warning systems such as Enhanced Ground Proximity Warning System,

have helped dramatically reduce CFIT accidents.

Similar technologies Boeing has implemented include predictive wind shear equipment that, along with improved wind shear training programs for pilots, has virtually eliminated that type of accident. Advances such as these in the design of flight deck systems help pilots avoid safety problems common in years past.

In our workplace, safety is just as important. More than five years ago, Boeing set out to reinvent production safety. The company reviewed its workplace safety data and found an increasing trend in workplace injuries. Boeing took a stand to stop that trend.

Through enhanced awareness, reporting processes for potential safety risks, "Incident and Injury Free" training, workforce readiness centers and other resources, we're trying to eliminate all workplace injuries.

**For example, eliminating free-standing ladders in the factory has reduced injuries by 29 percent.**

Aviation and workplace safety improvements like these are on display at Boeing's Safety Promotion Center. The center features interactive exhibits focused on sharing and advancing

PHOTO: MARIAN LOCKHART



Boeing's culture of aviation safety, product integrity and workplace safety.

I have the privilege of leading the regulatory administration and product safety teams for commercial airplanes at Boeing. Our role spans programs and functions to provide expertise, as well as promote a culture of safety and compliance.

When I visit the Safety Promotion Center, I contemplate our history of tremendous progress in aviation safety, and Boeing's role and culture of safety. I also reflect on the global aviation system that our products and services are a part of—and that Boeing has helped create through more than a century of commitment. 

Elizabeth Pasztor is vice president of Safety, Security and Compliance for Boeing Commercial Airplanes.



# Greg Hyslop

In the service of quality engineering and rigorous testing.

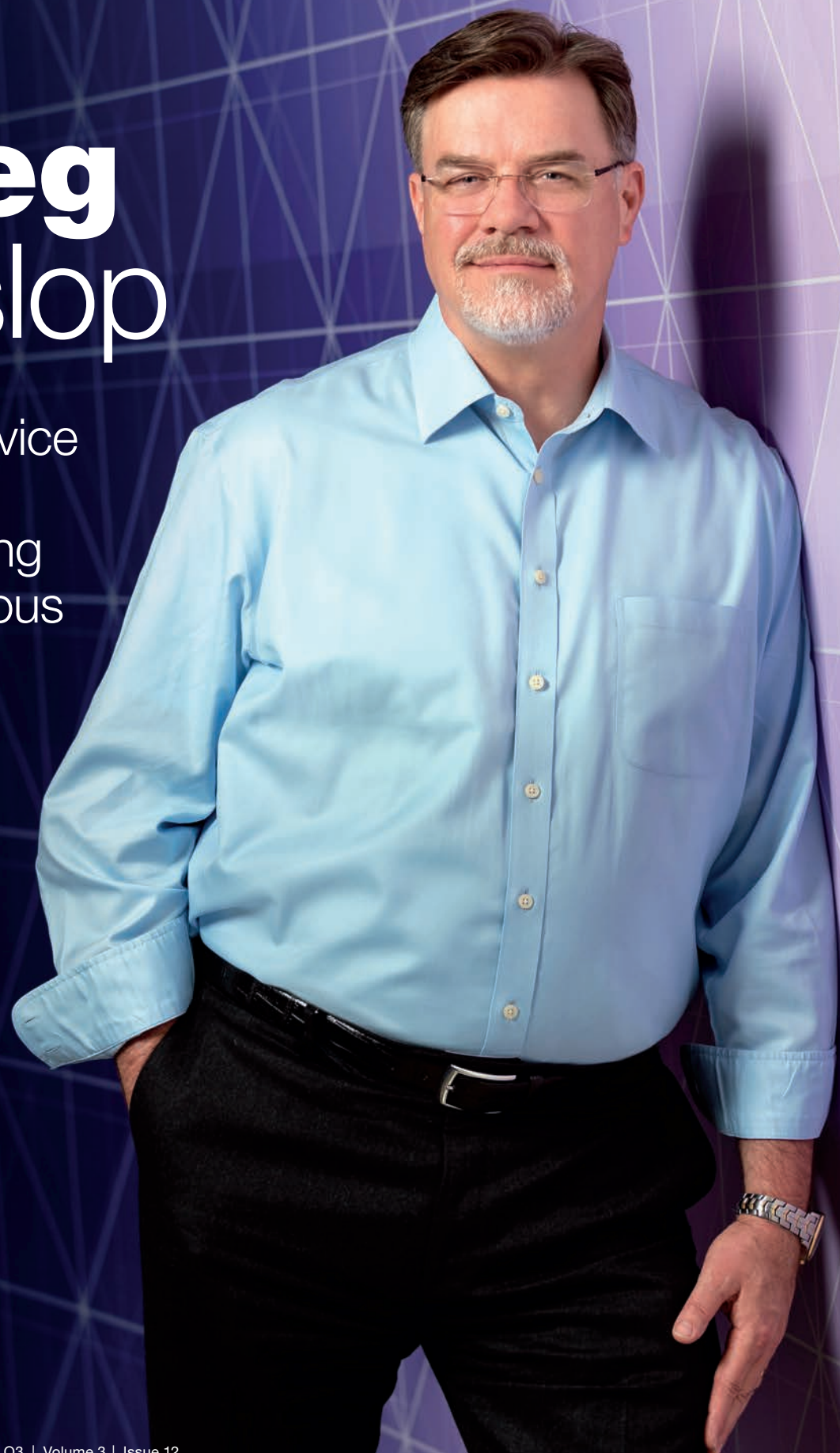

**Aviation authorities around the world grounded the 737 MAX aircraft after two fatal accidents. Boeing teammates have been intensely focused on safely returning the 737 MAX fleet to service.**

INTERVIEW BY JUNU KIM AND CANDACE BARRON | PHOTOGRAPHY BY PAUL GORDON

**Q&A** with Boeing's head of engineering and chief technology officer about the MAX, its return to service, and the effect of recent air accidents on the company and its technical team.

**Q What goes through your mind when something like this happens, and how did you react?**

**A** Lives depend on what we do, whether it is our commercial airplanes delivering millions of passengers safely to their destinations every day, or men and women who use our defense systems to protect freedom. So these events strike at the core of who we are at Boeing and affect us all very deeply.

For me personally, I think about it all the time—even when I am engaged in some other activity, it is always there in the back of my mind.

At a time like this I have to return to the basics; let the facts and data lead us to the right answer, and then trust my team to implement that answer.

We are committed to preventing this type of accident from ever happening again. Every one of us at the company works hard every day to uphold our core values of safety and quality, and these recent events have reinforced and intensified this commitment.

**Q How do you think this episode will change Boeing's processes?**

**A** Boeing has a strong problem-solving culture. There are a number of ongoing investigations that are getting to the root cause, and from there corrective actions will be identified and implemented. But I'll say this: How the software was developed and certified for the MAX was no different than what we've done many times before, and we followed the same FAA requirements and processes that have governed certification of previous new airplanes and derivatives. No corners were cut and everyone was doing their jobs.



As we do with any accident, we're going through a time for self-reflection, to see if there's something we need to change. I can say this: Because we're getting ready to fly another aircraft for the first time, our team is asking themselves, 'What more do we need to do in the buildup to first flight? What questions do we need to ask? Do we have all our bases covered? Is there anything we haven't thought of?'

For us as a learning organization, for our industry—as our industry learns from every accident—that's what makes air travel the safest form of transportation today. We don't want any accidents, so we will learn as much as we can, and we will change and improve.

**Q Will this ultimately change the company or its culture?**

**A** For everyone at Boeing, safety is No. 1. The safety, health and prosperity of the people our products touch—the flying public, the air crews, soldiers, astronauts, everyone—as well as our teammates who work every day to design and build our products, are always our first priorities. Our heritage as a company is built on a foundation of quality and safety. That has not changed, and it will never change. That's why our Boeing Engineering Code calls out the importance of safety and quality. We want to make it clear to everyone on our team that safety and quality are fundamental values that define who we are, what we do and what we believe in.

**Q It's been reported that there was a safety feature in the MAX software that Boeing made optional for airline customers? Can you explain that?**

**A** On every airplane delivered to our customers, including the MAX, pilots are provided with all flight data and information needed to safely operate the aircraft.

The reports you're referencing relate to the AOA (angle of attack) indicator option and the AOA disagree alert, neither of which are necessary for the safe operation of the airplane. They provide supplemental information only, and have never been considered safety features on commercial airplanes.

The Boeing design requirements for the 737 MAX included the AOA disagree alert as a standard, standalone feature, but the flight display software delivered to Boeing linked the AOA disagree alert to the AOA indicator, which is an optional feature on both the MAX and the NG. As a result, the AOA disagree alert would be active only if an airline opted for the AOA indicator.

**TEST AND EVALUATION**

Hyslop works with flight test engineers as they work to return the 737 MAX to service.



PHOTO: BOEING

**“ I fundamentally believe we will get through this, thanks to the people on our team. ”**

GREG HYSLOP

PHOTO: BOEING



**EMBRACING A NEW AIRCRAFT**

As with every new airplane, Boeing teammates gathered in Renton, Washington, in 2017 to proudly introduce the 737 MAX 9.

Boeing is issuing a display system software update, to implement the AOA Disagree alert as a standard, standalone feature before the MAX returns to service. When the MAX returns to service, all MAX production aircraft will have an activated and operable disagree alert and an optional angle of attack indicator. And all customers with previously delivered MAX airplanes will have the ability to activate the disagree alert.

**Q You've been with Boeing for almost 37 years and have seen your share of ups and downs. How does this period compare with previous challenges? And what thoughts do you have for people who are new to Boeing or are interested in joining the company?**

**A** This is the toughest time I've experienced in my career at Boeing. But I fundamentally believe we will get through this, thanks to the people on our team.

Our values like safety and quality are at the core of who we are, and that's why I think the things we're feeling this time are so broad and deep. But the company's had tough times in the past, and we got through them. And we'll get through this as well, because people trust us for who we are

and what we stand for.

I've been on recent engineering test flights where the MAX demonstrated the software, and so have other Boeing leaders, including Dennis (Muilenburg). I felt completely safe, and I had no doubts at all about getting on board the airplane because I trust our people.

When I say I trust our products, what I really mean is that I trust our people because it's people who put together those airplanes. It's people who write that software. It's people like procurement agents who write that spec that goes to the supplier that puts a part on that airplane. And I inherently trust our people do the right thing.

**Q There have been public suggestions that Boeing should rebrand the 737 MAX. What do you think about that?**

**A** We're proud of the MAX, and there are no plans to change that name. We will certify and implement the software update, and the MAX will be one of the safest airplanes ever to fly. 



# Salvo success for our Homeland

**In a March 2019 test, the U.S. Missile Defense Agency and Boeing launched two Ground-based Midcourse Defense system interceptors to destroy a threat-representative target.**

**BY SHEILA SHARP, CHIEF ENGINEER FOR GROUND-BASED MIDCOURSE DEFENSE  
BOEING DEFENSE, SPACE & SECURITY**

PHOTO: BOEING

The test is known as a “two-shot salvo” engagement. The target launched from Kwajalein Atoll in the Pacific Ocean while the interceptors launched from Vandenberg Air Force Base, California, more than 4,000 miles away.

The test was FTG-11, the most complex test of this system in its history, successfully executed with a set of objectives and technical advances that have been implemented through a decade of planning.

During this test of the U.S. Ground-based Midcourse Defense system, the lead interceptor destroyed the target reentry vehicle in space, just as it was designed to do. The trail interceptor evaluated the resulting intercept debris and remaining target objects. Not finding any other reentry vehicles, it selected the next most lethal object it identified and precisely struck that object.

This successful test of the GMD system demonstrated first-of-its-kind salvo intercepts of a complex, threatlike intercontinental ballistic missile target in space during midcourse flight.

## A crucial piece in the defense architecture

The United States is overlaid with defense systems architected to protect the lives of its population from missile attacks. Within that system, the GMD system is the United States' only operational missile defense program capable of defending the entire homeland (including Alaska and Hawaii) against long-range ballistic missile attacks.

The results of this test are a critical milestone that provide evidence for accomplishing the salvo doctrine within missile defense—a capable, credible deterrent against a realistic threat.

GMD system elements reach across 15 time zones and are linked by a terrestrial communication system consisting of over 20,000 miles of fiber optic cable, as well as a redundant satellite communications network. Ground-based interceptors are located at Fort Greely, Alaska, and Vandenberg Air Force Base, California. Command, control, battlement management and threat analysis support is provided by dual-node, human-in-control interface located at Fort Greely and in Colorado Springs, Colorado.

A total of 44 ground-based interceptors are currently in place. The ground-based interceptor is a multistage, solid fuel booster with an exo-atmospheric kill vehicle that launches toward the predicted location in space of the target. Once the kill vehicle is released from the booster, guidance data from ground support, fire control system components and on-board sensors direct closure with and destruction of the target warhead. The intercept occurs outside the Earth's atmosphere using only the kinetic force of the collision to destroy the target.

The technical complexity of this challenge has been compared to hitting a bullet with a bullet. The team working this system has employed tireless effort and inventive ideas to deliver integrated, synchronized missile defense systems and operations, providing a layered defense against multiple ranges of threats and in all phases of flight.

The summation of their vast technical knowledge, creativity and risk-mitigation approaches was demonstrated through ground and flight test campaigns, like the most

The technical complexity of this challenge has been compared to hitting a bullet with a bullet.

recent successful FTG-11 flight test. Without their knowledge, ingenious problem-solving and delivery, our evolved capabilities could be less effective in the face of increasingly sophisticated adversaries.

This is also personal. We have a shared dedication to protecting lives against advancing, complex threats, through the technological advancement of a system that must be relevant and capable to protect our nation and its people. IQ

Sheila Sharp is an engineering director in Boeing's Missile and Weapon Systems group, with experience in various space and security programs including Spacelab, Delta, International Space Station and satellites.

## Ground-Based Midcourse Defense Engagement Sequence

GRAPHIC: BOEING

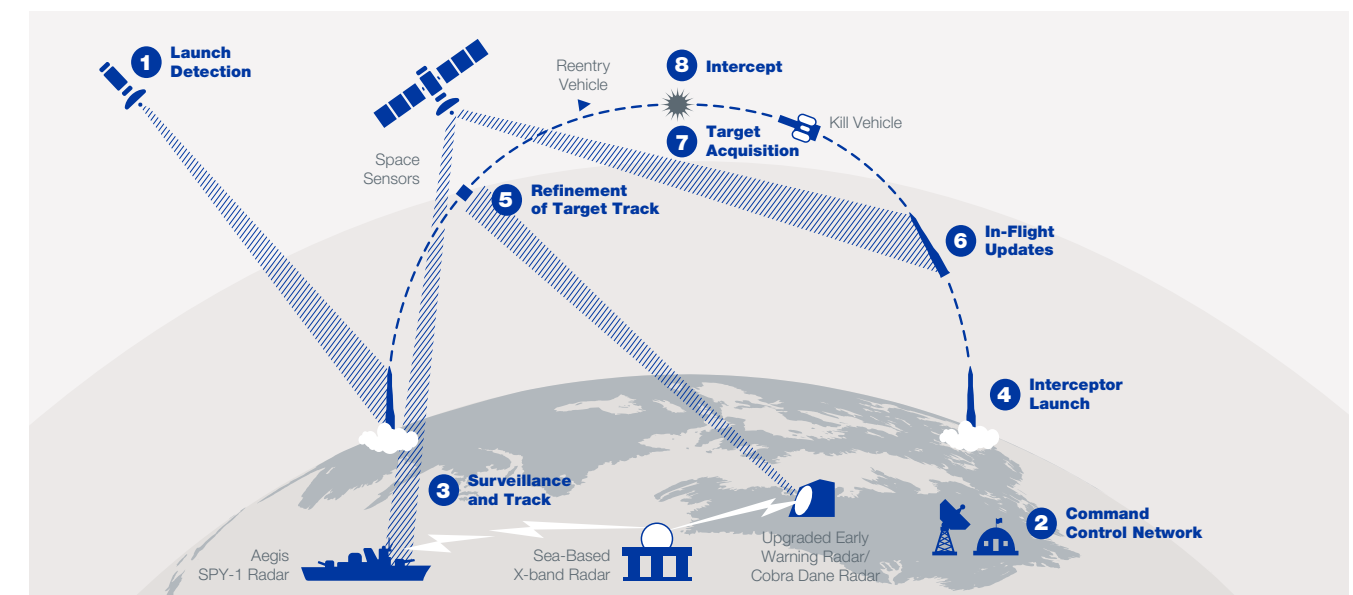



# Living by the Code

INTERVIEWS BY LAURA FENTON AND CANDACE BARRON

**Boeing's Engineering Code is a foundational doctrine uniting its technical staff around the world.**

## THE INNOVATOR'S PERSPECTIVE

We asked seven Boeing inventors to talk about what it means to practice engineering excellence.

From left: Samantha Schwartz; Carissa Pajel; Rogie Rodriguez-Quiñones; Daniel Alvarez; Om Prakash; Rosa María Rodríguez; and Robert Grip



## Millions of people fly on Boeing airplanes every day.

They trust those airplanes to get them safely to where they want to go—to conduct business, stay connected with family, and to travel and experience the world. The men and women serving in the defense of the United States and its allies rely on Boeing products and services to perform as expected.

This is why members of the Boeing Technical Community abide by a collective pledge to the Engineering Code. Because they create some of the most complex systems known to humankind, it's incumbent on them to ensure that the work they do is right, the first time and every time.

"Quality as a way of life" is about understanding requirements, complying with processes and standing behind the work. It's about checking work before it leaves individual teams to avoid downstream problems and rework. And it's about having the courage to call attention to any issues that threaten these values.

Technical issues rarely resolve themselves. More often, even minor unresolved issues can grow into larger problems. Similarly, opportunities can be fleeting—once they're gone, their benefit may be lost forever. Effective engineers

identify and address issues and surface potential opportunities as early as possible to meet commitments and remain competitive.

Ultimately, it's the personal responsibility of Boeing engineers and technical staff to remain vigilant, focused and dedicated, while maintaining the highest standards of health, safety and well-being.

There are seven essential clauses to the Code. We sat down with seven Boeing innovators to ask them what these parts of the Code mean to them personally. Here are their stories in their own words.



PHOTO: KAREN DUCEY

**THE CODE PART 1**

**I deliver results with excellence and live the enduring values.**

Engineering drives Boeing's purpose and mission to connect, protect, explore, and inspire the world through aerospace innovation. As a Boeing engineer, I acknowledge and accept the responsibility for creating and supporting Boeing's products and services, which connect people through travel and communication, protect the rights and freedoms of a global community, enable the human race to explore the mysteries of our universe, and inspire current and future generations of innovators. I am dedicated to the pursuit of excellence and recognize that my work directly affects our products and services, our teammates who design and produce them, our suppliers with whom we collaborate, and our customers who operate and maintain them. I will act according to the Boeing Code of Conduct and all applicable laws and regulations, and I will perform my work according to the highest standards of professional integrity. 

**Samantha Schwartz**

**JEPPESSEN, BOEING GLOBAL SERVICES**  
**SPECIALTY: COMMUNICATIONS AND NETWORK MANAGEMENT**  
**DENVER, COLORADO, USA**

As a former airline pilot, I have a heightened understanding of the importance of the products and services we create, and the impact we can have on the lives of our customers. I am driven to create safe products, enhance situational awareness and increase the efficiency of our customers' operations. I work with customers to understand their pain points and deliver on Boeing's commitments. I share my work across business units and collaborate globally to enhance and integrate aeronautical information onboard the flight deck. I protect Boeing's future through securing intellectual property that will transform the aerospace industry.

**“ I work with customers to understand their pain points and deliver on Boeing's commitments. ”**

**SAMANTHA SCHWARTZ**



PHOTO: KAREN DUCEY

**THE CODE PART 3**

**I am a champion.**

I am a champion for safety, quality, affordability, productivity, and maintainability across the entire life cycle of our products. I play an integral role in ensuring the integrity and safety of our products. I leverage the enterprise for the best ideas that can be implemented and replicated. I use the size and complexity of our company as an advantage and never an excuse. I look for ways to streamline my work processes without cutting corners or compromising quality. 

**Rogie Rodriguez-Quiñones**

**BOEING RESEARCH & TECHNOLOGY**  
**SPECIALTY: METALS**  
**HUNTSVILLE, ALABAMA, USA**

I'm responsible for creating products that achieve the highest engineering and quality standards. I look for ways to innovate, improve efficiency and affordability without compromising safety and quality. Currently, I'm developing a test method that will accelerate the development of additively manufactured parts. I also support younger generations as a role model and technology leader through the Boeing Familia organization. We lead lunch-and-learn events where Boeing leaders share their career path to inspire early-career employees. And most importantly, I'm dedicated to developing disruptive solutions to change the world and to push the boundaries of Boeing and the industry.

**THE CODE PART 2**

**I am a leader.**

I take pride in supporting and enabling priorities that deliver the most value to our customers. I perform my work with enthusiasm, curiosity, and creativity. I make it a priority to connect my daily work to the goals of the project, program, business unit, and the enterprise. I relentlessly pursue innovative solutions that move my team, Boeing, and the customer forward. 

**Carissa Pajel**

**BOEING RESEARCH & TECHNOLOGY**  
**SPECIALTY: CHEMICAL TECHNOLOGIES**  
**SEATTLE, WASHINGTON, USA**

My mother, who was an executive for a long time, taught me that being a leader is more than talking fluently—being a leader also means being a listener, and listening before reacting. Through listening, we can determine the real problem and solve it in an efficient and effective manner. As a chemical engineer specializing in sealants, I am passionate about my technology. By listening to my stakeholders, I am empowered to pursue innovative solutions supporting process flow, cost reduction efforts and safety for the company and the customers.

PHOTO: J.P. BOND







PHOTO: PAUL PINNER

**THE CODE PART 5****I am a collaborator.**

I communicate candidly, honestly, and thoughtfully. To operate as One Boeing, I collaborate with others from the global enterprise. I build trust in those around me by giving and accepting constructive feedback. To hold myself accountable, I put finding the right answer ahead of being personally right. 

**Om Prakash**

**BOEING GLOBAL TECHNOLOGY  
SPECIALTY: STRUCTURAL MATERIALS,  
CONCEPTS AND ARCHITECTURES  
BANGALORE, INDIA**

I honor my commitment by understanding the needs of customers. Their challenges are the foundation of the innovations I develop. Regular communication gives me awareness of situations and makes me responsive to customer needs. As Boeing's research team has grown over the years in India, I identified multiple collaborative research efforts between Boeing and a number of Indian research entities. Factoring Boeing needs and expertise of partner organizations, we initiated projects and developed solutions in areas such as die-less sheet metal forming and computer-assisted defect recognition in inspection of engineering components. All these efforts have led to successful technology growth and transitions.



PHOTO: MARIAN LOCKHART

**THE CODE PART 4****I am a listener.**

I demonstrate trust in order to build enduring relationships with my customers and my teammates. I first seek to understand the point of view of others, and I work toward a mutually acceptable solution while preserving relationships. I use facts and data to develop innovative solutions that create value. I always honor my commitments to our customers and my teammates. 

**Daniel Alvarez**

**MILLENNIUM SPACE SYSTEMS,  
BOEING DEFENSE, SPACE AND SECURITY  
SPECIALTY: ELECTRONICS AND EMBEDDED SOFTWARE  
EL SEGUNDO, CALIFORNIA, USA**

We have two ears but one mouth because we should listen more than speak. Whether building satellites to provide high-speed internet on airplanes, enabling communication to the International Space Station or serving national security interests, the best ideas are often within the collective team wisdom. Once, a technical issue arose on my team and two people debated one hour before others could speak. A soft-spoken engineer mentioned she had seen a similar issue on another program and offered a suitable solution. It was an illustration of a universal tenet: Encourage and listen to capture the best ideas, designs and results.

PHOTO: GUILLERMO BLANCA



“ The glory of doing something by yourself is short; it’s much better to accomplish things as a team. ”

ROSA MARIA RODRIGUEZ

**THE CODE PART 6****I empower others.**

I empower others around me by sharing what I know with colleagues across Boeing. I operate in a multi-disciplinary manner, I seek diverse viewpoints and opinions to help solve the challenges I encounter, and I foster a culture of inclusiveness and trust. I recognize my teammates' performance and appreciate the excellence they bring. I celebrate wins, big and small, while learning from mistakes. 

**Rosa Maria Rodriguez**

**BOEING GLOBAL TECHNOLOGY  
SPECIALTY: SYSTEMS ENGINEERING AND ANALYSIS  
MADRID, SPAIN**

Everyone has a different role and style—some people like to be in the front line, some like a lower profile. I have teammates in China, India, Spain, Brazil and the United States, all who add significant views to bring the project forward. Distance does not stop our team. To empower a team is also about trust; it's about giving autonomy and shared responsibility, and confidence in yourself and others to make this happen. To empower a team makes everyone confident and stronger. The glory of doing something by yourself is short; it's much better to accomplish things as a team.



PHOTO: PAUL PINNER

**THE CODE PART 7****I am an innovator.**

I have high expectations of myself and higher aspirations for my future. I am courageous and proactive in identifying risks and mitigating issues while pursuing opportunities. I am a steward of Boeing's technical heritage and lineage, and I apply, share, protect, and build upon this foundation by embracing change and competition, learning from failure, and striving to continuously innovate and improve. I am proud to know that my work changes the world. 

**Robert Grip**

**BOEING COMMERCIAL AIRPLANES  
SPECIALTY: FLIGHT DESIGN, ANALYSIS AND  
CERTIFICATION/QUALIFICATION APPROACHES  
LONG BEACH, CALIFORNIA, USA**

As an innovator with the commercial airplanes advanced concepts team, I improve current products, develop new ideas and explore markets outside our core businesses. Perseverance to pursue new ideas, even if not immediately accepted, is very important to be an innovator, while also recognizing that collaboration with talented Boeing experts can determine unworkable ideas, or greatly improve valuable ideas. An unworkable idea can be a significant source of learning. Knowing what doesn't work is also part of Boeing's technical knowledge. I want my talents to contribute to the great work we do at Boeing.

“ Perseverance to pursue new ideas, even if not immediately accepted, is very important to be an innovator. ”

**ROBERT GRIP**

## Selections from the **Boeing Technical Journal**

The Boeing Technical Journal is a peer-reviewed periodical for Boeing subject matter experts to capture and share knowledge. Research coverage includes all manner of commercial and defense product development, and products and services spanning land and sea, to air and space, and cyberspace.

**Contributing Authors****Checklists to Enhance Safety**

**DANIEL J. BOORMAN** is a Boeing Technical Fellow, engineer and production test pilot specializing in electronic checklists and flight deck procedures.



**WILLIAM Y. HIGGINS** is a recently retired Boeing trainer and technical writer specializing in the development and implementation of critical checklists.

**Determination of Thermoplastic Composite Crystallization Process Limits for Dynamic and Isothermal Cooling Processes**

**CHRISTOPHER H. CHILDERS** is a technical lead engineer for thermoplastic composite materials and principal investigator for Boeing research and development of thermoplastic composite materials.

The Journal is a proprietary publication, but the articles on the following pages are summaries of technical papers approved for public release and available online at Boeing.com.

# Checklists to Enhance Safety

## Summary

BY DANIEL J. BOORMAN | WILLIAM Y. HIGGINS

The concept of the checklist is so simple, and is used in so many ways today that talking of “critical” checklists does not leave much of an impression. Incorporating checklists in high-hazard environments has been one of the most influential innovations to enhance safety in recent times.

The defining moment leading to the innovation of using a formal checklist occurred in 1935.

The Army Air Corps was to award a contract to build its next-generation long-range bomber, and three companies were bidding for the contract: the Douglas Aircraft Co. with the Douglas DB-1, the Glenn L. Martin Co. with the Martin 146, and Boeing with the Model 299. The 299 flew farther and faster, and it carried more payload than either of the other two entries. It was acknowledged that the advanced, sophisticated Boeing four-engine airplane was the inevitable winner. The Army had already planned to order at least 65 of Boeing’s aircraft, once the formalities of an official flying demonstration were completed.

On Oct. 30, 1935, at Wright Airfield in Ohio, the Model 299 lifted off, climbed to 300 feet, then stalled and crashed killing two of the five crew members, including the pilot. An investigation determined that pilot error caused the crash. While tending to the airplane’s

multitude of switches and controls, the pilot forgot to release a new locking mechanism on the airplane’s elevator controls. Critics declared that the Model 299 was “too complex to fly.”

Boeing initially lost the contract, but some remained convinced that the aircraft could be safely operated. A group of Boeing engineers and test pilots developed a simple approach: They created a pilot’s checklist with critical action checks for taxi, takeoff and landing. They believed that this airplane was not too complex to fly, but was too complicated to be left to a pilot’s memory.

A technicality in the selection process allowed Boeing to build and test another 12 Model 299 aircraft. With the checklist in hand, Boeing and Air Corps pilots went on to fly the initial 12 airplanes a total of 1.8 million miles without an accident. The Army ultimately ordered almost 13,000 of the aircraft, which were designated the B-17 and gave the Allies an air advantage in World War II as they helped carry out a devastating bombing campaign across Nazi Germany.

The checklist became a permanent and mandatory tool, for both routine and emergency conditions, to be used by all pilots in the Boeing fleet, in all of military aviation, and soon after in commercial aviation as well.

This paper examines the use of checklists in various high-risk environments, and pre- and post-checklist implementation comparisons. We will also discuss human factors studies that form the foundation for the use of checklists, as well as draw parallels between what implementation teams in other fields have discovered when integrating checklists and the positive impact checklists can have on safety. The issues examined and conclusions documented can be used to support the development of critical checklists throughout any industrial application.

### The following categories are indicative of the multiple uses of checklists:

- **Procedural checklists:** Excessively long, complex or critical tasks performed only occasionally require “read-and-do” checklists (those checklists not done from memory, but the checklist is read and the various tasks performed sequentially) to ensure specific tasks in both normal and non-normal situations are accomplished.
- **Preparation checklists:** Multiple-step situations require checklists to ensure all variables are performed as desired; for example, shopping lists, trip planning, and group or individual communication sessions.
- **Problem-solving checklists:** Multiple-point, question-type checklists are used for troubleshooting complex procedures or tasks to pinpoint what went wrong, areas of difficulty, or solutions to barriers blocking forward movement.
- **Prevention checklists:** Critical checklists address errors, mistakes, mishaps in high-hazard work areas that can result in injury or death to users or neighbors, destruction of property, or impact to reputation or continued business success.

Each of these different uses has a particular purpose, and each has value and meaning as intended. While the use of checklists is present in almost every industry, extensive studies examining their effectiveness and the science of how to develop effective checklists are almost nonexistent except in the medical field, nuclear power and aviation industry. Our primary focus in this paper is to examine the effectiveness of prevention checklists in these industries.

For example, in only the last two decades has the medical industry adopted a serious stance in preventing surgical errors by widespread adoption of using checklists.

In response to a shocking study published in 2000 that reported an estimated 44,000 Americans died each year as a result of preventable medical errors, a medical team at Johns Hopkins Hospital introduced several improvements, included and guided by a checklist termed the Comprehensive Unit Based Safety Program.

The program resulted in reducing what is known as central-line associated bloodstream infection, a life-threatening condition, to nearly zero over four years. The Johns Hopkins results has led other medical institutions to implement similar patient safety programs. Additionally, in 2008, when the World Health Organization deployed its Surgical Safety Checklist, various health care systems, cultures and operating venues reported a 53 percent reduction in postoperative mortality and a 64 percent reduction in morbidity.

The following implications, drawn

from this analysis of processes undertaken to build a safety culture and in the use of checklists in numerous industries, provides insightful principles and practical strategies on how the development of critical checklists can have a positive impact on the development of a safety culture:

### 1. Understanding checklist use

- a. The use of checklists will not eliminate all accidents in the lab, test facility, production line or wherever they are implemented. Accidents will still happen even when users make decisions consistent with best practices because risk cannot be completely eliminated.
- b. Training classes and feedback can positively change personal behavior. Practical issues encountered during the implementation of checklists can be minimized by effective training.
- c. All employees must make decisions as to what steps, if any, they need to take based on a mental representation of the factors known or hypothesized in the ever-changing or semi-constant state of their equipment at any given point in time.

d. “No repetition of incidents” must be a guiding principle, and if an incident occurs it is necessary to learn from it to prevent the same incident from happening in the future.

e. Internalization and generalization is central to the process of change. A change in communication can get people talking about safety differently than they communicated before an effective safety awareness program was implemented.

f. Emphasis must be placed on the importance of checklist use with reminders of situations where deviations from checklists occur and how they can be misused.

### 2. Organizational changes that support checklist use

- a. It is crucial that performance evaluation and theoretical rhetoric proclaim the same message.
- b. Engaged senior leadership is essential to sustaining a culture of safety and the involvement of all levels of staff is critical to a successful safety and checklist initiative rollout.

SOURCE: WORLD HEALTH ORGANIZATION

**Surgical Safety Checklist**

World Health Organization | Patient Safety

**Before induction of anaesthesia** (with at least nurse and anaesthetist)

- Has the patient confirmed his/her identity, site, procedure, and consent?
  - Yes
- Is the site marked?
  - Yes
  - Not applicable
- Is the anaesthesia machine and medication check complete?
  - Yes
- Is the pulse oximeter on the patient and functioning?
  - Yes
- Does the patient have a:
  - Known allergy?
    - No
    - Yes
  - Difficult airway or aspiration risk?
    - No
    - Yes, and equipment/assistance available
  - Risk of >500ml blood loss (7ml/kg in children)?
    - No
    - Yes, and two IVs/central access and fluids planned

**Before skin incision** (with nurse, anaesthetist and surgeon)

- Confirm all team members have introduced themselves by name and role.
- Confirm the patient's name, procedure, and where the incision will be made.
- Has antibiotic prophylaxis been given within the last 60 minutes?
  - Yes
  - Not applicable
- Anticipated Critical Events
  - To Surgeon:
    - What are the critical or non-routine steps?
    - How long will the case take?
    - What is the anticipated blood loss?
  - To Anaesthetist:
    - Are there any patient-specific concerns?
  - To Nursing Team:
    - Has sterility (including indicator results) been confirmed?
    - Are there equipment issues or any concerns?
- Is essential imaging displayed?
  - Yes
  - Not applicable

**Before patient leaves operating room** (with nurse, anaesthetist and surgeon)

- Nurse Verbally Confirms:
  - The name of the procedure
  - Completion of instrument, sponge and needle counts
  - Specimen labelling (read specimen labels aloud, including patient name)
  - Whether there are any equipment problems to be addressed
- To Surgeon, Anaesthetist and Nurse:
  - What are the key concerns for recovery and management of this patient?

FIGURE 1. The WHO Surgical Safety Checklist.



Determining the best way to proceed in a complex operational setting is to acknowledge expertise and experience as an essential foundation to using checklists.

- c. Safety and checklists must be ingrained in organizational culture until everyone can say that checklists are just “a part of how we do business.”
- d. One key to organizational success in the use of checklists is to continue to search for errors, know their error rates, monitor them after implementing safety innovations, and give feedback to all staff so they know the science behind the checklists is valid. The use of checklists is not the endgame; reduced error rates are.
- e. A key feature of a successful safety and checklist initiative is its rejection of a command-and-control regime where workers are simply told they are to use a checklist and expected to go and do it. Instead, they need to be encouraged to develop checklists that fit their own unique challenges and culture.
- f. To improve safety, it is critical that we shift from a perception where the prime cause of accidents is user errors to thinking of errors as the consequence of many factors that combine to create conditions for accidents, and how to reduce those conditions.

- g. A zero mindset to injuries, accidents and occupational illnesses is necessary and a belief that all injuries and occupational illnesses are preventable.
  - h. Committed peer champions placed as “safety experts” in labs, test facilities or manufacturing plants will stimulate discussions on safety.
- 3. Benefits of checklists**
- a. Ensuring that all critical tasks are carried out.
  - b. Encouraging a non-hierarchical team-based approach.
  - c. Enhancing communication, catching near misses or potential complications early enough to correct them, and encouraging the use of technologies to manage anticipated and unanticipated complications.

- d. Empowering workers to control their own safety, become more comfortable with their safety-related choices, and more likely confront anyone asking them to perform an unsafe procedure when a safer one is available.

Checklists are good to ensure tasks get done, but determining the best way to proceed in a complex operational setting is to acknowledge expertise and experience as an essential foundation to using checklists.

Pre-planned procedures and checklists cannot replace the necessity of users bringing to bear diagnostic and response strategies in real time based on their experience, collaboration and attentiveness when the confluence of influencing factors on any given piece of equipment, test or facility requires it. 

This article was published in the November 2016 edition of IQ. To read and download the complete paper:

“An Analysis of the Effectiveness of Checklists when combined with Other Processes, Methods and Tools to Reduce Risk in High Hazard Activities”

Please visit [boeing.com/IQ](http://boeing.com/IQ).

# Determination of Thermoplastic Composite Crystallization Process Limits for Dynamic and Isothermal Cooling Processes

## Summary

BY CHRISTOPHER H. CHILDERS

Over the past several years, as Boeing has greatly increased its usage of structural thermoplastic composite materials, the potential design space for thermoplastic composites has grown. So new materials have been required to meet this expanding need.

Historically, the processing of thermoplastic composite materials was determined by a trial-and-error approach, used to determine the consolidation parameters for the multiple consolidation methods, where each method requires a unique set of parameters. While this process window could be used to create high-quality laminates or parts in a stable manner, it might not have been the most optimal cycle possible.

For the legacy structural thermoplastic composite material with a polyether ether ketone (PAEK) polymer matrix, this iterative approach was used to generate the processing window for three unique processes used for thermoplastic composites: continuous compression molding; press consolidation; and thermal stamp forming.

However, this iterative approach is both expensive and time consuming. As new materials are developed, a more rapid,

cost-effective approach to determining the process window is required.

This paper interrogates the relationship between composite laminate consolidation (or thermal forming) cooling process parameters and crystallization kinetics of thermoplastic polymer composite matrix materials.

In general, all three of the processing methods mentioned rely on the use of high temperatures and pressures (greater than 350°C and 15 bar) to convert the thermoplastic pre-preg or semi-preg to a consolidated laminate.

After some time at elevated temperature, the now-consolidated laminates must be cooled. For semi-crystalline polymer materials the cooling step is critical. Cooling controls

the percent crystallinity that determines the mechanical performance of the composite. The crystallinity also directly influences any residual stresses in the composite part. To generate crystallinity upon cooling, the three processes use both dynamic (non-isothermal) and isothermal cooling. Thus understanding how the two cooling methods impact crystal growth is critical to developing a rapid, low-cost methodology to define process conditions for new materials.

One approach to understanding thermoplastic composite crystallization kinetics and processing is to model crystallization behavior at various cooling rates and isothermal hold temperatures. Multiple kinetic models exist, including the Flynn-Wall-Ozawa,

As the potential design space for thermoplastic composites has grown over time, new materials have been required to be developed to meet the expanding need.

Nakamura, and Avrami models. The Avrami crystallization kinetic model is the most often selected for PAEK materials, such as poly ether ether ketone (PEEK) and poly ether ketone (PEKK).

One of the main factors responsible for the common use of the Avrami Crystallization Kinetics Model is the inclusion of both dynamic and isothermal kinetics models. Both models are based on crystallization rates determined by heat flow measurements made using differential scanning calorimetry (DSC). During DSC cooling, the percent crystallinity,  $\alpha$ , is measured by monitoring the change in heat flow over time/temperature. When correlated to the time component of the experiment, the following relationship has been established and is the basis for the Avrami crystallization kinetics model:

$$\ln(-\ln(1-\alpha)) = n\ln(t) + \ln(Z) \quad [1]$$

Where:  $\alpha$  = percent crystallinity

$t$  = time

$Z$  = Avrami temperature constant

$n$  = Avrami correction factor

In the case of isothermally cooled processes,  $Z$  is directly related to the isothermal hold temperature. For dynamically cooled processes, a correlation factor to correct for cooling rate must be applied:

$$\ln(Z_c) = \frac{\ln(Z)}{|\beta|} \quad [2]$$

Where:  $\beta$  = cooling rate ( $^{\circ}\text{C}/\text{time}$ )

The  $n$  and  $Z$  terms are determined by a plot of  $\ln(-\ln(1-\alpha))$  versus  $\ln(t)$  where the slope is equal to  $n$  and the intercept equal to  $\ln(Z)$ . These terms are unique for each isothermal hold temperature and cooling ramp rate but the values tend to become more similar at very slow cooling ramp rates of high isothermal temperatures as very slow cooling rates force the slowest crystallization kinetics. To complete the kinetic model, the exponential terms are applied to the crystallization half-time equation shown below in Equation 3. The relationship between half-time and processing for the thermoplastic composites is discussed in this paper.

$$t_1 = \left( \frac{\ln(2)}{Z} \right)^{\frac{1}{n}} \quad [3]$$

For this work, DSC was used to generate dynamic and isothermal Avrami crystallization kinetics models for thermoplastic composite consolidation and thermal forming processes. These models were then applied to determine the crystallization half-time and establish robust process windows for all three for a new structural thermo-plastic composite material. This model and approach will ultimately reduce the cost and time frame for development and implementation of consolidation/forming processes for new thermo-plastic composite materials.

For the experiments, unidirectional carbon-fiber-reinforced thermoplastic composite pre-preg was used as received. The pre-preg material was manufactured to and is in compliance with industry standard requirements. Specifically, the pre-preg utilizes a PAEK polymer matrix with an intermediate modulus carbon fiber.

#### Dynamic Cooling Differential

#### Scanning Calorimetry

Dynamically cooled differential scanning calorimetry experiments were conducted on thermoplastic unidirectional pre-preg materials to determine crystallization kinetics at various cooling rates. Experiments were completed on a PerkinElmer DSC 8500 with helium purge gas. The instrument was calibrated to measure heat flow up to a cooling rate of  $750^{\circ}\text{C}/\text{min}$  using Indium and Sapphire standards. (Temperature calibration was completed by the manufacturer.)

For all dynamic experiments, the thermoplastic composite pre-preg samples of approximately 8-15 mg in size were placed in a crimped aluminum sample pan. The sample was heated to  $410^{\circ}\text{C}$  at  $10^{\circ}\text{C}/\text{min}$  in the DSC to achieve complete melt.

Samples were then cooled at a variable rate to  $140^{\circ}\text{C}$  using the cooled helium purge gas. The cooling rates targeted were 5, 10, 20, 30, 40, 50, 60, 80, 100, 150, 250, 350, and  $500^{\circ}\text{C}/\text{min}$ . After cooling to  $140^{\circ}\text{C}$ , the samples were heated back to  $400^{\circ}\text{C}$  at  $10^{\circ}\text{C}/\text{min}$  to ensure that no cold crystallization was present. (Cold crystallization is defined as any crystallization event that occurs during the heating of the material below the melt temperature.) Transitions were identified and integrated using the standard PerkinElmer analysis software and Origin 9.0.

#### Isothermal Cooling Differential Scanning Calorimetry

Isothermally cooled DSC experiments were conducted on the same instrumentation as described for the dynamic cooling experiments. Also as previously described, 8-15 mg samples of thermoplastic composite pre-preg material were placed in a crimped aluminum sample pan. The samples were heated to  $410^{\circ}\text{C}$  at  $10^{\circ}\text{C}/\text{min}$  in

PHOTO: BOEING



One approach to understanding thermoplastic composite crystallization kinetics and processing is to model crystallization behavior at various cooling rates and isothermal hold temperatures.

#### SAMPLES

Pictured are examples of thermoplastic composite formed parts.

the DSC to achieve complete melt.

Samples were then cooled at  $650^{\circ}\text{C}/\text{min}$  to the isothermal hold temperature and held for one hour. After the hold, the samples were cooled to room temperature and then heated to  $400^{\circ}\text{C}$  at  $10^{\circ}\text{C}/\text{min}$  to ensure that no cold crystallization was present. Due to the small mass of the samples and instrumental setup, minimal thermal lag was observed between the set point temperature and the sample temperature as measured by the instrumentation, with a maximum differential of  $6.95^{\circ}\text{C}$  between the sample and set point (at a set point of  $140^{\circ}\text{C}$ ). Isothermal hold temperatures targeted were: 150, 175, 200, 225, 250, 270, 280, 290, 300 and  $325^{\circ}\text{C}$ . Transitions were then identified and integrated using the standard PerkinElmer analysis software and Origin 9.0.

Experiment results are explained and discussed in the full report available online.

Thermal-based process window limitations were recommended for both dynamically and isothermally cooled processes. These process windows are based solely on the melt and

crystallization kinetics of the polymer and must be validated mechanically.

However, this methodology eliminates entirely the guess and check methods that were previously used. Under the guess and check system, parts would have to be fabricated at multiple tool temperatures and evaluated thermally and mechanically until the process window was determined.

By the implementation of Avrami kinetic modeling, we can determine the extremes of the process and then optimize, reducing cost and implementation time for all semi-crystalline thermoplastic

composite materials. Furthermore, this work demonstrates that for full implementation of this specific PAEK, changes to the tooling concepts of the various consolidation processes are required to more efficiently manage the heat transfer to and from the composite material. Lastly, the methodology developed in this work has been used to provide processing parameters via continuous compression molding, press consolidation and thermal stamp forming. **IQ**

To read and download the complete Boeing Technical Journal paper titled:

“Determination of Thermoplastic Composite Crystallization Process Limits for Dynamic and Isothermal Cooling Processes”

Please visit [boeing.com/IQ](http://boeing.com/IQ).



# Boeing pilots the birth of biofuel for aviation's sustainable growth

**In a little more than a decade, the use of biofuels in commercial aircraft has gained critical ground.**

BY PAUL MCELROY, BOEING WRITER

It began in fall 2006, when a group in the United Kingdom called Plane Stupid staged protests criticizing short-haul flights—part of a chorus of environmental protests across Europe urging people to stop flying.

Boeing heard the message. And against that backdrop, it began developing a comprehensive environmental strategy, which included sustainable aviation fuel as a new way to reduce life-cycle carbon dioxide emissions from airplanes by up to 80 percent.

Aided by Boeing's technical expertise, Virgin Atlantic flew the world's first airline biofuel test flight on a 20 percent blend made from coconut and babassu oil in one fuel tank of a 747-400 from London to Amsterdam on Feb. 24, 2008.

Boeing then supported three more test flights with Air New Zealand, Continental and Japan Airlines to gain certification of biofuels for commercial use. The airplanes were equipped with engines from CFM, Pratt & Whitney and Rolls-Royce to gather broader results. The fuel, derived from waste

animal fats, was called HEFA (for hydro-processed fatty acid esters and free fatty acids).

Fast-forward a decade, and Boeing began offering customers the option of powering their commercial airplane delivery flights with sustainable aviation fuel to spur its use and support the industry's drive to protect the environment.

**"This is another step in our journey to encourage the adoption of sustainable fuels and help commercial aviation earn its license to keep growing,"** said Sheila Remes, who leads Boeing Commercial Airplanes strategy.

When it takes delivery of its first three Boeing 737 MAX airplanes, Alaska Airlines, the first participant in the initiative,

plans to fly them on a blend of biofuel and traditional jet fuel to its hub at Seattle-Tacoma International Airport.

Boeing is offering biofuel to customers accepting new airplanes at its delivery centers in Seattle and Everett, Washington, as well as using biofuel for certain flight-test operations at Boeing Field in Seattle.

In January, Etihad Airways became the latest operator to demonstrate the viability of biofuels by flying the world's first passenger flight using sustainable fuel made from a plant that grows in saltwater. The flight from Abu Dhabi to Amsterdam on a 787-9 Dreamliner culminated a three-year research project supported by Etihad, Boeing and several other organizations.

The United Arab Emirates project seeks to develop aviation biofuel to reduce carbon dioxide emissions and lessen the country's need to import nearly 85 percent of its food. Fish raised at a unique aquaculture farm in the UAE fertilize the plant and provide food for the desert nation.

"The technology shows significant promise to transform coastal deserts into productive farmland supporting food security and cleaner skies," said Sean Schwinn, Boeing International vice president of strategy and market development.

Sustainable aviation fuel progressed from the first Virgin Atlantic test flight in 2008 to everyday use in less than a decade—with Boeing playing a leadership role in its birth and growth. Test flights, research and rigorous reviews by airlines, airplane and engine manufacturers, refiners, regulators and others led to HEFA's certification for commercial use in July 2011.

"It was very challenging because no one had created a biologically based aviation fuel before," said Jim Kinder, Boeing Senior Technical Fellow, who is an expert in aviation fuels. "But we knew it would work. In fact, biofuel has a higher energy density and performs better than Jet A."

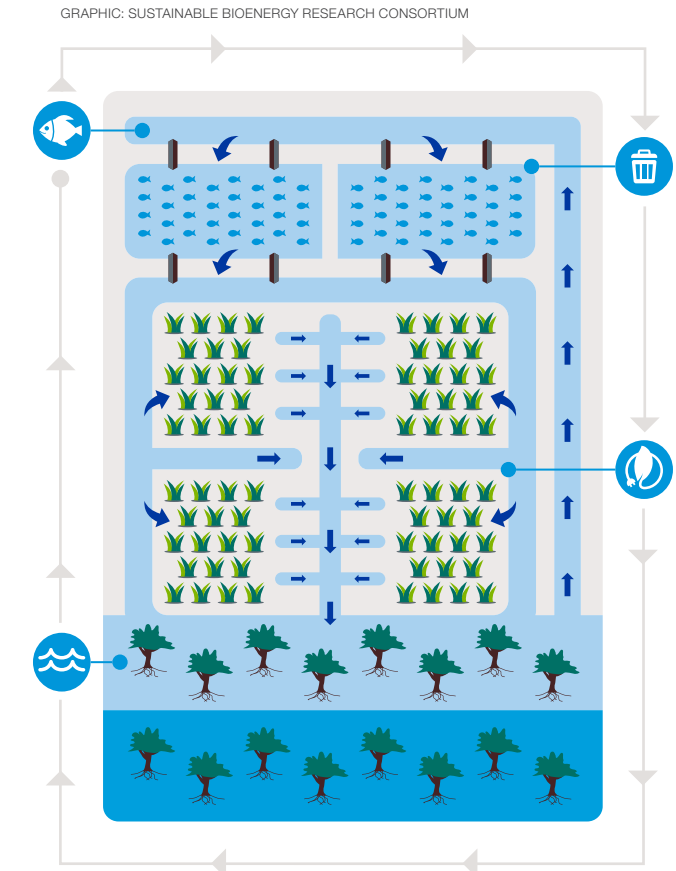

## The Integrated Seawater Energy And Agriculture System

- Supporting Aquaculture**  
Seawater is pumped into ponds to grow fish and shrimp for food.
- Fish Waste as Fertilizer**  
Nutrient-rich fish waste flows into fields of halophyte plants to act as fertilizer and biologically clean the effluent.
- Desert-Loving, Salt-water Tolerant Plants**  
Halophyte plant biomass and oils are harvested for aviation biofuel production and other products.
- Mangroves Provide Carbon Sequestration**  
The effluent is diverted into cultivated mangroves before being discharged back into the sea, further removing nutrients and providing valuable carbon storage.

### Biofuel's blooming path to powering the world's jet fleet

It has been almost 10 years since Boeing ran its first biofuel test flight. Here is a timeline of key milestones in the development and growth of this sustainable product.

**FEB. 24, 2008**  
Virgin Atlantic flies the world's first biofuel test flight on a commercial airplane using biodiesel.



**SEPTEMBER 2009**  
Aviation's first biofuel approved for use.

**2009-10**  
Boeing works with Air New Zealand, Continental and Japan Airlines to conduct biofuel test flights on Rolls-Royce, Pratt & Whitney and CFM engines.

**JULY 1, 2011**  
Research analysis from test flights leads to approval of a second type of biofuel known as HEFA (hydro-processed fatty acid esters and free fatty acids).



**2011**  
KLM, Lufthansa, United and Alaska Airlines fly the world's first biofuel-powered passenger flights during the summer and fall—all on Boeing airplanes.



**2014-16**  
Three more biofuel types approved for aviation.

**2015**  
Several airlines commit to biofuel purchases totaling 1.6 billion gallons through 2019.



**JANUARY 2016**  
Norway's Oslo Airport becomes first in the world to regularly offer biofuel.

An early decision by stakeholders proved key, Kinder said. “Biofuels have to be drop-in. That way, they can be blended directly with fossil fuel without modifying the airplane, its engines or airport fueling systems.”

After HEFA’s certification, various airlines began flying passenger flights using a blend of biofuel and traditional fuel to demonstrate their environmental commitment and market interest. Starting in 2015, several operators bought nearly 1.7 billion gallons of biofuel to use over the next five years. Norway’s Oslo Airport became the first in the world to regularly offer it to all departures in 2016—followed by Los Angeles, Stockholm and Bergen, Norway.

Around the time of Virgin’s pioneering flight, industry leaders, including Boeing and Airbus, voluntarily set three goals to reduce commercial aviation’s 2-percent share of global emissions: Improve fuel efficiency by 1.5 percent annually from 2009 to 2020; stop the growth of emissions next year; and cut them to half of what they were in 2005 by 2050.

In the decade following that flight, global air travel doubled to more than 4 billion passengers annually. Airlines have been modernizing their fleets, however, and the industry has taken other steps to improve operational efficiency—enabling aviation to exceed its 1.5 percent goal.

But those 12 million people a day who fly now are expected to double again in 20 years, according to industry estimates. The growth in emissions poses a challenge to achieving the other goals. And as evidence of climate change increases, anti-flying sentiment has surged anew.



#### MARCH 2016

United Airlines begins sharing its purchase of up to 915 million gallons of biofuel over five years to all airlines at Los Angeles International Airport, providing a small amount to every departure.

#### 2017

Airports in Stockholm, Sweden, and Bergen, Norway, regularly offer biofuel.



#### SPRING 2018

Boeing’s eco-Demonstrator test platform, a FedEx Express 777 Freighter, flies the world’s first 100 percent biofuel flight on a commercial airplane.

#### 2019

Etihad Airways flies the world’s first passenger flight using sustainable fuel made from a saltwater plant.

#### MARCH 2019

Boeing announces it will offer biofuels to customers taking delivery of new airplanes in the Puget Sound region.

As a prelude to its technical work, Boeing started collaborating with industry stakeholders on regional roadmaps to develop biofuel. The first initiative involved partnerships with Alaska Airlines; the ports of Seattle and Spokane, Washington, and Portland, Oregon; Washington State University; and others to create a group called Sustainable Aviation Fuels Northwest.

That effort became a blueprint. Boeing has worked with several dozen partners around the world since then to develop similar roadmaps for processes meeting strict third-party sustainability certifications. Feedstocks have included Brazilian sugarcane, a nicotine-free tobacco plant grown in South Africa and the unique ecosystem in the UAE that creates biofuel from desert plants irrigated with seawater, among others.

“We’re catalyzing supplies tailored to regional resources, which can be scaled commercially at prices competitive with traditional jet fuel,” said Sean Newsum, who directs the environmental strategy for Boeing Commercial Airplanes. “Some production pathways have the added benefit of reducing other types of pollution, such as making biofuel from household waste and carbon captured in industrial off-gassing.”

Boeing is also working to gain certification for HEFA+. Called green diesel in ground transportation, certification would make a price-competitive, sustainable supply available that could meet more than 1 percent of global aviation needs.

“I think we’re nearing a tipping point,” Newsum said. 

# Patent spotlight

Check out a few of Boeing’s latest ideas and technical breakthroughs recently granted or published by the U.S. Patent and Trademark Office.

“As the human mind continues to transcend limitations, we will work to empower the creative spirit of today’s innovators by protecting their hard work.”

WHITE HOUSE PROCLAMATION FOR  
WORLD INTELLECTUAL PROPERTY DAY,  
APRIL 26, 2019

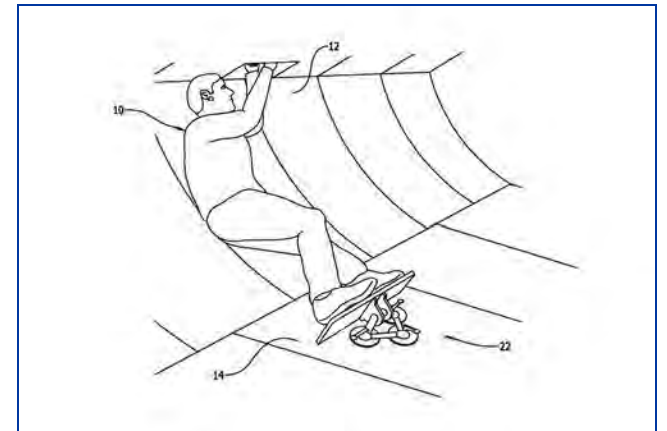

## Cargo Floor Brace Tool

U.S. PATENT: 10,190,325

INVENTORS: KURT B. HRUBANT,  
WILLIAM R. WHITE

Performing overhead work, like installing headliners and cargo sidewalls above an inclined surface or near the top of a curved surface, requires whoever is doing the work to constantly reposition themselves after sliding down. This is not only fatiguing and time-consuming, but it can result in muscle and joint strains because the person could end up positioning themselves in improper ergonomic posture to complete the work.

This recent Boeing patent describes how to prevent a person from sliding down an inclined surface as they perform overhead work. This brace tool is a rigid frame of sufficient strength to hold the weight of a person. A platform is mounted to the frame and can be adjusted relative to the frame. Suction cups are secured to the bottom of the frame.

The brace tool is positioned and the suction cups are locked into place on the inclined surface. The person performing the work can then stand or kneel on the platform before releasing the brace tool to move to a different area to work. This new tool provides a comfortable, safe and ergonomically correct environment for performing overhead work on an inclined surface while saving time and preventing unnecessary exertion.



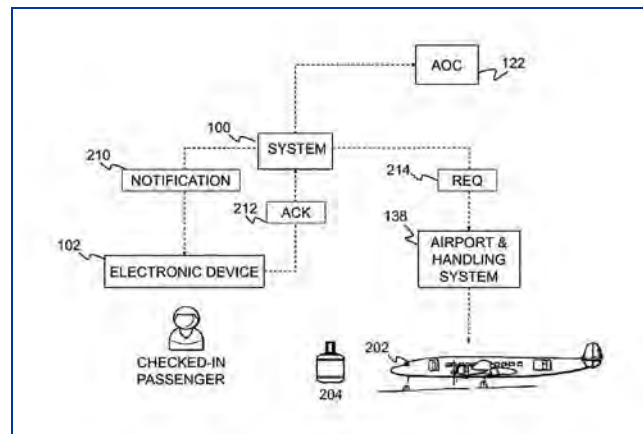

## Computer-Implemented Method and System for Managing Passenger Information

**U.S. PATENT PENDING**  
**INVENTORS: PABLO COSTAS, ENRIQUE CASADO, MIGUEL VILAPLANA**

Traveling is hectic. Traffic to the airport is crazy. Lines at ticketing and security are long. And sometimes your connection is on the other side of a huge airport. Airlines and their passengers need to be able to communicate with each other seamlessly.

This recently published patent application, which is based on a European application, describes a system and computer-implemented method that enables a collaborative exchange of information between passengers and an airline operation center. This invention describes how to compute the likelihood of missing a flight or connection based on the knowledge of passenger location, flight status, current average airport delay, and actual and planned inbound and outbound traffic.

First, a connection between a user's electronic device and an airline data server is established. The user is identified as a passenger for a departing flight at the airport. The passenger gets flight status, provides their actual location information and receives a probability indicator as to whether they will make or miss their flight.

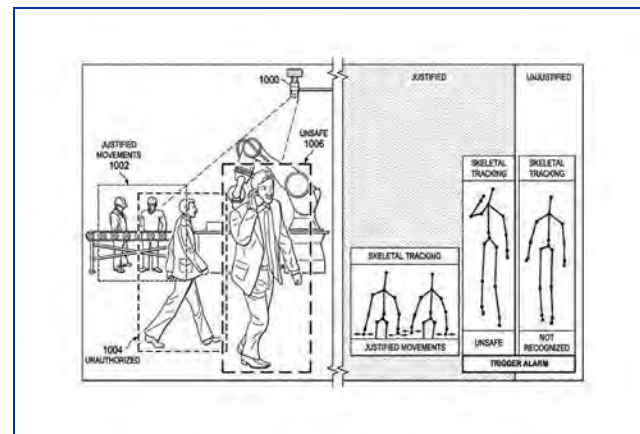

## Using Human Motion Sensors to Detect Movement When in the Vicinity of Hydraulic Robots

**U.S. PATENT: 10,186,130**  
**INVENTORS: MELISSA H. LEWIS, JOHN DESMOND WHELAN**

Hydraulic robots are typically used in large-scale manufacturing. While humans and hydraulic robots can coexist and interact productively, safety is always a concern. Warning signs, safety protocols and fenced-off areas remind humans to be vigilant. While some robots have sensors that alert when someone or something is near, many fail to distinguish objects from humans and as a result may report an excessive number of false positives.

This recently granted Boeing patent describes a system that detects when a human is near a hydraulic robot. The system includes sensors and a computer. The sensor system distinguishes human skeletal positions from non-human object positions. The computer is configured to determine whether they are present in a predetermined area and determine whether a false positive has occurred. If the computer determines that a false positive has not occurred, then it will initiate an action, such as issuing an alert, or slowing or stopping the robot.

In another approach, the system can distinguish among different types of human movement. Instead of "motion recognition" that simply recognizes whether any kind of movement has occurred, this system uses "movement recognition," which means it can recognize a specific movement. For instance, movement recognition can determine if the movement is acceptable (for example, a motion of feeding parts into a machine) or potentially unsafe (for example, a motion of someone walking by while talking on their phone).

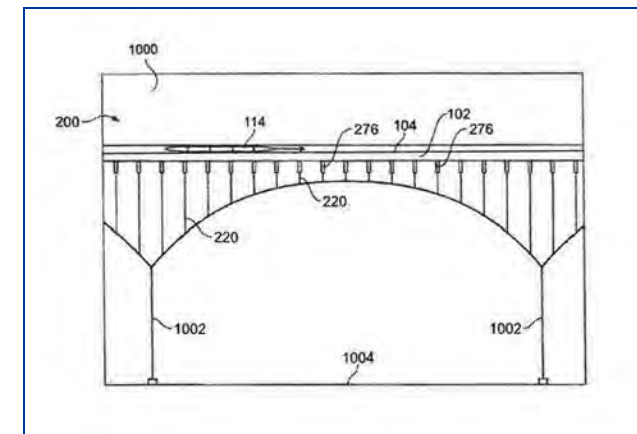

## Support Systems and Methods for a Transportation System

**U.S. PATENT: 10,189,484**  
**INVENTOR: ROBERT ERIK GRIP**

Magnetic levitation is a form of transportation in which a vehicle is moved without ever contacting the ground. In one application of magnetic levitation systems that is being planned for the future, a vehicle travels inside vacuum tubes to reduce and even eliminate aerodynamic drag on the vehicle. However, the tube might vertically deflect as the vehicle travels through it, and such deflections may be unsettling to passengers. Proposed solutions to reduce tube deflections, such as increasing the size and weight of the tube or decreasing the space between support columns, can require considerably more resources and may not be cost-effective.

This recently issued Boeing patent describes a system and method for reducing deflections as a vehicle travels through the tube. The system is composed of a suspension cable that extends between a first and second support tower or ground supports. The vehicle is configured to travel through the interior channel of the tube. A tension support member has a first end coupled to the suspension cable and a second end coupled to the vacuum tube through an actuator. The tension support member exerts force to pull the tube up toward the suspension cable as the vehicle goes by. The actuator thus reduces deflections of the tube by adjusting the tension force as the vehicle travels through the interior channel under the tension support member.

A suspension bridge design with actuated vertical members provides for stiff and effective support to transport tubes. Moreover, the design eliminates a need for a large number of supports connected to the ground, which not only is more economical but might allow for the tube to span over water.

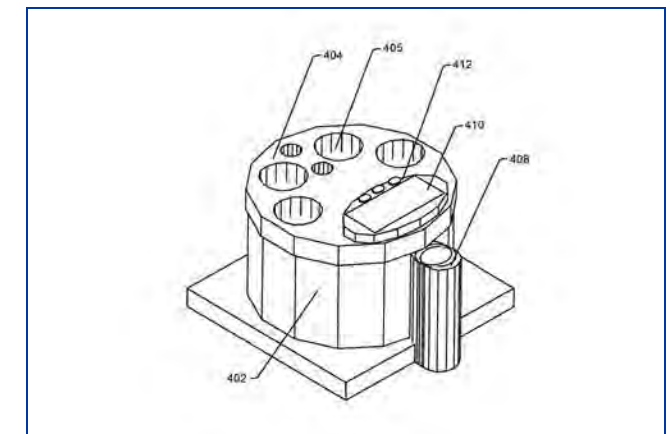

## Multifunction Programmable Foodstuff Preparation

**U.S. PATENT: 10,206,539**  
**INVENTOR: GEORGE WILSON FREAS II**

Conventional food preparation methods require multiple space-consuming containers and appliances and are not substantially automated. Current ingredient dispensers and mixers typically cannot operate in low or zero-gravity environments that exist on the International Space Station or deep space missions. This newly issued Boeing patent describes a better way to automate food preparation in both terrestrial and extraterrestrial contexts that could be necessary for humans living in space.

Three distinct embodiments are described in the patent: 1) Flight payload version for low-gravity and space environments; 2) ground-based cook pot/freezer that can be used in widebody airplanes; and 3) single-serving, hand-held mug for either environment.

The apparatus is a cylindrical container with a cavity configured to store the food ingredients. Some versions use a mixing blade and a plunger. The blade mixes and moves the ingredients to the inside walls of the cylindrical container to allow thermal exchange via thermoelectric Peltier devices. The plunger remains stationary at the bottom end of the container until the food preparation is complete, at which time the blade is stowed at the front, and the plunger is used to draw the food out of the cylinder. The thermoelectric Peltier devices are mounted directly on the exterior walls of the cylindrical container with heat sinks that may be connected to a thermal loop to aid in dissipating thermal energy.

Not only does this method provide a way to automate food preparation in one container, but the apparatus can also be programmed to clean itself.

# Batteries included

## A spacewalk and power upgrade for the International Space Station.

BY EBONY BOWENS,  
ELECTRICAL SYSTEMS ENGINEER  
BOEING DEFENSE, SPACE & SECURITY

We watched intently from NASA's Johnson Space Center in Houston, Texas, as astronauts Nick Hague, Anne McClain and Christina Koch worked 200 miles (322 kilometers) above us on the International Space Station during two separate spacewalks.

From my spot at the Mission Evaluation Room's Phoenix console, I saw them install new, lithium-ion batteries that will give the station new life. It is an honor and a privilege to be a part of the team that made this possible.

The reason for the upgrade? Eight solar arrays convert solar energy to electrical power for the space station. As the station orbits around the Earth, it is frequently not in direct sunlight. During this eclipse period (about 30 minutes of every 90-minute orbit), rechargeable batteries provide the station with continuous power to sustain life-support systems and experiments.



PHOTO: NASA

The lithium-ion batteries are a Boeing-initiated upgrade to the previous nickel-hydrogen ones. They will dramatically increase the station's operating efficiency and help ensure it remains operational—and able to welcome commercial crew spacecraft—until 2030 and beyond.

Lithium-ion cells can store a lot more energy than nickel-hydrogen, and can be charged and discharged more rapidly. They also aren't as prone to the "memory effect," which occurs when a battery is recharged before it is fully empty, diminishing its overall capacity.

The new batteries, developed in partnership with supplier Aerojet Rocketdyne, launched in September 2018 aboard a Japan Aerospace Exploration Agency HTV cargo craft.

My team and I developed the methods used by astronauts to install and activate the batteries on orbit. We also led the creation of procedures and flight rules, building physical models to support astronaut training ahead of real-time battery installation. This preparation proved vital, as astronauts were tasked with troubleshooting earlier work and upgraded power systems during a third spacewalk just over a week later.

Pursuing a lifelong dream of working in the space industry, I joined Boeing's International Space Station program in 2016 after working as an intern and electrical engineer on the product development team in our commercial airplanes part of the business.

“I wanted to contribute to the future of human spaceflight, particularly in making sustainable missions on the surface a reality.”

KAVYA MANYAPU,  
TEST ENGINEER AT BOEING HOUSTON

The knowledge I gained of battery capabilities, tools and reconditioning procedures used to create electrical bundles for airplanes was something I turned to when developing battery procedures for the space station. Engineering standards are incredibly robust and unique when you're dealing with a spacecraft, but the experience I had developing procedures for aircraft allowed my team to deliver better results to our NASA customer.

With the batteries successfully installed on the orbital platform, my team at Boeing's Houston site will conduct annual capacity tests from the ground and perform troubleshooting procedures if needed. 

## Boeing-developed spacesuit material to be tested in harsh space conditions

A unique material developed by a Boeing engineer to protect spacewalkers has been launched to the International Space Station for its most challenging test yet.

Kavya Manyapu, a Boeing test engineer in Houston, Texas, designed the material to shield astronauts from dust, radiation and other hazards when they leave the safety of their spacecraft to explore the surface of the moon and Mars. This is a different challenge from the one posed to astronauts inside a spacecraft where they can wear thinner garments.

“I wanted to contribute to the future of human spaceflight, particularly in making sustainable missions on the surface a reality,” Manyapu said.

Launched in April aboard a Cygnus cargo spacecraft, two small 2-by-2-inch (5-by-5-centimeter) samples of materials will be positioned outside the space station. They will stay there for months exposed to the harsh conditions of space, including drastic temperature changes, constant bombardment by cosmic rays and a complete lack of any kind of atmosphere. In other words, all the things that a spacesuit faces during a mission.

The new material, which can be used in spacesuits as well as space habitats, comes at a time when NASA is developing mission architectures to send astronauts to the surface of the moon within five years and to explore the lunar region in a sustainable fashion.

The material relies on carbon nanotubes and other conductive fibers to interlock tightly in certain conditions without causing the astronauts to lose critical mobility as they move around inside their suits. During Apollo, moonwalkers' spacesuits collected lunar dust that would bind the fibers and limit their movement.

Manyapu developed the technology as part of her doctoral study in aerospace sciences from the University of North Dakota. She and Boeing Technical Fellow Leora Peltz have two U.S. patents and one pending based on the research.

– Steve Siceloff



# From concept to business: Boeing HorizonX India Innovation Challenge

BY ANKUR KANAGLEKAR, STRATEGY DIRECTOR  
BOEING INDIA

Fresh, customer-oriented thinking coupled with new technologies has unlocked new business models, forever changing industries once considered too difficult to disrupt because of the high barrier to entry—like aerospace and defense.

Boeing HorizonX launched in 2017 to meet that challenge—to assess disruptive innovations and business strategies for Boeing, seek unique business opportunities for the company's aerospace technology and make targeted investments in new ventures.

Since its inception, Boeing HorizonX has invested in more than 15 early- and growth-stage startups in areas such as autonomous systems and space-based communications.

India is a natural strategic focus for Boeing HorizonX. This country's startup economy is thriving and one of the largest in the world. The aviation and aerospace industry in India is growing in leaps and bounds. For example, in terms of percentage growth of passenger traffic, India outpaces every other country. As India's economy grows and incomes rise, more and more people will opt for air travel, creating a greater

PHOTO: BOEING



#### XR IN INDIA

A representative of Merxius, a Boeing HorizonX India Challenge winning startup, displays its extended reality product, Red, to investors and customers during an event in August 2018.

market not only for aircraft, but also for related product and service businesses.

Just as importantly, India has immense talent in engineering, information technology and product development, along with a rich nexus of crucial disruption “enablers.” These incubators, accelerators, government offices and policies, universities, and other research institutions form an ecosystem to nurture the innovation potential of that talent. The Boeing India Engineering Technology Center (BIETC) is a key piece in that ecosystem, as well.

With that strategic backdrop, in November 2017, on the eve of the Global Entrepreneurship Summit in Hyderabad, Boeing HorizonX launched the “India Innovation Challenge 1.0.” Boeing invited startups across India to submit innovative ideas in nine focus areas crucial to the future of aerospace and aviation, such as passenger experience, unmanned and autonomous systems, aircraft maintenance and industrial internet of things (IoT).

Boeing also encouraged its own technology teams in BIETC to participate in the challenge through an internal incubator designed to turn

early-stage ideas into full business concepts that could compete with those from Indian startups. The challenge resulted in an overwhelming response from 82 startups, as well as more than 110 ideas submitted by Boeing internal teams. The ideas focused on solving India's unique problems in aerospace and aviation, such as IoT-based solutions to optimize India's congested airports, crowdsourced reviews for unpiloted aerial vehicle services and carbon fiber 3D printers for low-volume production.

The submissions displayed the dynamism, zeal and innovative potential in India for technology-driven market disruption. Gathering good ideas was only the first part of the challenge, as ideas are only the first step toward robust product and service offerings that can succeed in the marketplace.

For example, one of the submissions began as an airplane that could capture data by flying autonomously over industrial clusters, ports, railways and power systems to help track assets and provide workflow progress. After numerous conversations with potential customers and Boeing subject matter experts during a 90-day internal incubator program, the idea became a service offering.

Domain expertise in designing and manufacturing aerospace products and services is still nascent in India. One cannot develop successful aerospace technology, let alone the end product, without deep understanding of the aerospace engineering domain, systems engineering, program management, customers' buying behaviors all across the value chain, the regulatory environment, and more. The challenge provided Boeing an opportunity to nurture the startup talent and ideas like this flyover data service—and helped the participants learn entrepreneurial behaviors and best practices in the real industry business environment.

## Global Scale

### Upgrading the Chinook fleet in Spain

Boeing will upgrade Spain's fleet of Chinook helicopters, adding features such as a digital automatic flight control system, common avionics architecture system and advanced cargo handling. The modernization will align the Spanish fleet of the tandem-rotor, heavy-lift helicopter with those of the United States and many other nations around the world.

### Boeing investment in UK startup for space-based connectivity

Boeing HorizonX Ventures has invested in Isotropic Systems, a London-based firm that provides space-based global connectivity services. By taking advantage of optical beam steering, Isotropic's user terminals simultaneously connect with several different satellites, enabling low-cost, mass-market broadband connectivity for consumers. Isotropic is the second UK-based startup to join the Boeing HorizonX portfolio, following Reaction Engines, whose SABRE rocket engine recently passed the first phase of high-temperature testing.

### Royal Air Maroc implements crew efficiency analytics

Royal Air Maroc will deploy Boeing AnalytX-powered crew solutions to create optimized work duties and improve staffing efficiency. Modules such as Crew Tracking help airlines detect, resolve and follow up on changes to crew planning. Provided by Boeing subsidiary, Jeppesen, the data-driven crew optimization tools allow airlines to manage in real time the constraints of crew rosters to support their entire fleet.

In April 2019, Boeing launched another challenge, known as the BUILD (Boeing University Innovation Leadership Development) Program, targeting students and faculty across India's engineering colleges and early stage startups. Through the BUILD Program, we want to support the virtuous cycle of students and faculty starting ventures and successful entrepreneurs working with universities to coach aspiring entrepreneurs.

The focus of this program is to minimize idea mortality. We can do that by providing resources like innovation

best practices; providing subject matter expertise, tools and methods; coaching on business practices; and providing opportunity to directly work with customers. For example, Boeing HorizonX contributed elements of the internal incubator program along with an innovation curriculum for universities and startup accelerators to use. This initiative will help nurture the innovation ecosystem in small- and medium-sized cities and rural areas in India where a wealth of talent needs only support to prosper. 





PHOTO: BOEING



PHOTO: BOEING

Spreading  
the word to  
change  
the world.



PHOTO: AMERICAN PHYSICAL SOCIETY



PHOTO: BOEING



PHOTO: BOEING

**From the top, left to right:**

**LADIES OF AEROSPACE**

Boeing project manager Vera Fair, from Huntington Beach, and her daughter, Kaylee, pose with Heidi Capozzi, senior vice president of Boeing HR, at a Women in Aviation International event in March.

**LETTERING IN TECHNOLOGY**

Sean Thomas, Adaugo Anyamele, Adetomilola Popoola, show off their Boeing pride at the National Society of Black Engineers 45th annual convention career fair in Detroit in March.

**PHYSICS IN THE FAMILY**

Associate Technical Fellow Carol Anway (left) was recently elected a fellow of the American Physical Society. She is pictured here at the APS March meeting with her father, physicist Allen Anway, and APS Fellow Ichiro Takeuchi.

**A QUICK FIX**

Technician Tom Buus competes in the final challenge of the Aerospace Maintenance Competition at 2019 MRO Americas trade show in Atlanta, Georgia in April.

**ALOHA FOR SCIENCE**

Colette De La Barre, technology domain leader for platform systems and subsystems, talks to students about her work in astronautics at Boeing and as a U.S. Air Force officer and professor. The STEM Symposium 4 Girls at Sacred Heart Academy on O'ahu in February included 230 students and teachers from 35 schools.

**Test pilots must know how to fly, as well as how to make it fly**

# Aptitude at altitude

In those old, black-and-white newsreel days, a pilot took off in an experimental aircraft not really sure if he was coming back. That was when the pilots were the engineers and the engineers were the pilots. They designed, tested and tweaked new methods of flight all at the same time, almost as fast as their airplanes could fly.

Some things never change. Even with all the advances in powered flight making commercial air travel the safest form of transportation today, every Boeing test pilot still needs a high level of technical expertise, as they did a century ago.

Boeing test pilots not only fly, but they use their technical skills to fulfill an intellectual curiosity and to push the laws of science to seemingly defy gravity.

Test pilots are important translators, taking what the aviators in the field say that they need from the airplane and translating that to other engineers who are designing the airplane.

Most pilots simply love to fly. But test pilots don't fly just for the sake of flying. Their sense of satisfaction comes with accomplishing specific technical goals on every test flight. When talking about the safety of those aboard, nothing is more important than making sure all Boeing aircraft work the way they need to. **IQ**

**-CANDACE BARRON**



PHOTO: BOEING

**PILOT-ENGINEERS THEN**

Capt. Richard "Buzz" Nelson, chief Project Pilot for the 767, on the 767 flight deck with his test crew. Nelson, an engineer and pilot, was responsible for all engineering flight-test activities related to all models of the Boeing 767.

PHOTO: BOEING



**ENGINEERING TEST FLIGHTS NOW**

Jim Webb, chief pilot for commercial airplanes, and Jennifer Henderson, 737 chief pilot, prepare for takeoff in a 737 MAX 7. Like all of Boeing's test pilots, they are both aviators with engineering degrees.



Wideband Global SATCOM (WGS)

# YOUR FUTURE IS BUILT HERE

The satellite innovations developed by our people change lives everywhere.  
Join Boeing and you can change the world.

[boeing.com/careers](https://boeing.com/careers)



Boeing is an Equal Opportunity Employer. Employment decisions are made without regard to race, color, religion, national origin, gender, sexual orientation, gender identity, age, physical or mental disability, genetic factors, military/veteran status or other characteristics protected by law.

